



COMMERCIAL / RESIDENTIAL SIDEWALK DRAWING

CITY OF AMARILLO BUILDING SAFETY DEPARTMENT

Sidewalk Fee: \$60
Fee is subjected to an additional \$10 Technology Fee

COMMERCIAL SIDEWALK

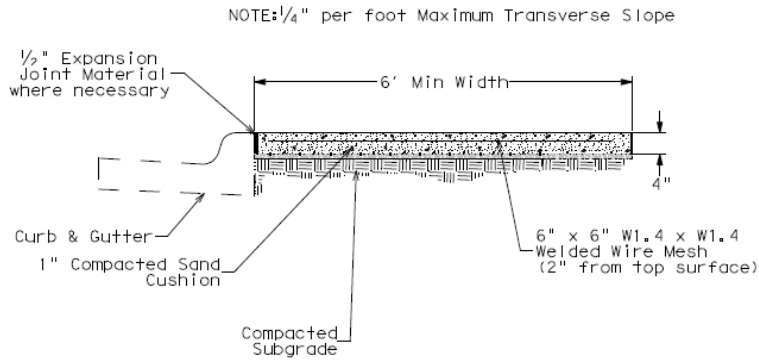

RESIDENTIAL SIDEWALK

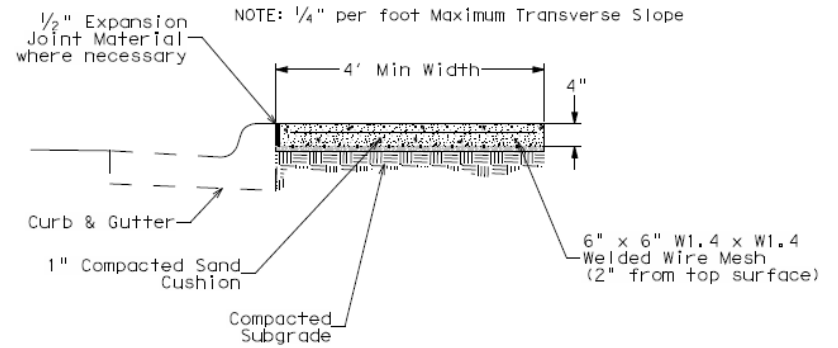

NOTES:

1. All flatwork shall use Class A concrete unless otherwise detailed or specified. Concrete requirements for flatwork of any other class shall be labeled on the plans and called out in the specifications.
2. No reinforcement wire will be closer than three inches (3") to edge of concrete.
3. 1/2 preformed expansion joint material shall be placed at intervals not to exceed thirty feet (30') in the sidewalk or as directed by the engineer. Scoring joints (dummy joints) shall be placed in sidewalks with jointing tools at intervals not to exceed five feet (5').
4. 1' sand cushion shall be wetted and forms oiled prior to placing any concrete.
5. When sidewalk is located at Back of Alley Apron or Back of Driveway, increase thickness to six (6") inches minimum.



If Box is Checked

Flatwork Permit requires a separate stand-up curb & gutter inspection from the CP&DE dept, Call 806-378-9334 to schedule a curb & gutter inspection before pouring concrete. (An attached drawing should show new curb & gutter length and location)

Flatwork inspection is required before pouring concrete.