



20 PSF Snow Load Region

Instructions for Use:

This snow load chart is designed to be used in conjunction with other City of Amarillo hand outs that require specific snow/live load values to determine structural requirements for construction. This chart is divided in four sections: headers, beams, footings and rafters/joists. Each section has details which show the general construction layout relevant to finding the minimum structural requirements for that specific use.

Provide a permit application, a site plan (drawn with dimensions per example), and any additional information as required for your particular type of permit and signed pages of requested information from this handout.

- All the tables in this document are based on IRC 2015 tables utilizing Hem-fir #2 lumber.

Structural strength of lumber weakest to strongest (spruce-pine fir #2)

4" Wide			Weakest ↓ Strongest	6" Wide		
(2)2x4	(2)2x10	4x14		(3)2x4	(3)2x12	6x14
4x4	4x10	3 1/8x9	(3)2x6	6x10	5 1/8x10 1/2	
(2)2x6	(2)2x12	3 1/8x10 1/2	6x6	(3)2x14	5 1/8x12	
4x6	4x12	3 1/8x12	(3)2x8	5 1/8x7 1/2	5 1/8x13 1/2	
(2)2x8	2x14	3 1/8x13 1/2	(3)2x10	6x12	5 1/8x15	
4x8	3 1/8x7 1/2	3 1/8x15...	6x8	5 1/8x9	5 1/8x16 1/2...	

The City of Amarillo assumes no responsibility for any extra costs that may be associated when the requirements of this handout are used for your construction project. If you wish to deviate from any proposed details or requirements OR feel this handout exceeds requirements for your specific site this handout may not be used. One (1) set of site specific construction plans shall be provided with your permit application.

This design may be used at the owners risk as a minimum design in lieu of specific construction plans and engineering design furnished by the owner.

Final approval is subject to field inspection and compliance with all relevant codes, laws and ordinances. Requirements on this handout based on 2015 IRC codes.

20 PSF Snow Load Region

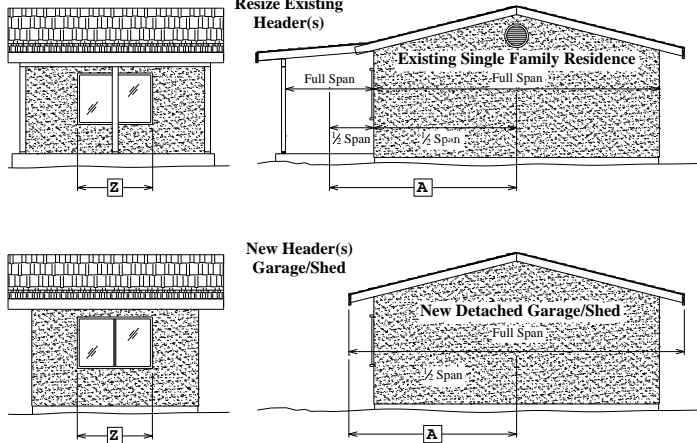

New and Existing Header

General Notes

- Existing headers must be resized to support any additional loads
- All requirements based on 15psf dead load

Minimum Size 4" Headers

[Z]	[A]				
	6'	7'	8'	9'	10'
4'	4x4	(2)2x6	(2)2x6	(2)2x6	(2)2x6
6'	4x6	(2)2x8	(2)2x8	(2)2x8	(2)2x8
8'	4x8	(2)2x10	(2)2x10	(2)2x10	4x10
10'	(2)2x10	4x10	(2)2x12	(2)2x12	4x12
12'	(2)2x12	4x12	(2)2x14	3 1/8x7 1/2	4x14
14'	(2)2x14	4x14	3 1/8x9	3 1/8x9	3 1/8x10 1/2
16'	3 1/8x9	3 1/8x9	3 1/8x10 1/2	3 1/8x10 1/2	3 1/8x10 1/2
	11'	12'	13'	14'	15'
4'	(2)2x6	(2)2x6	(2)2x6	4x6	4x6
6'	4x8	4x8	(2)2x10	(2)2x10	(2)2x10
8'	4x10	(2)2x12	(2)2x12	(2)2x12	4x12
10'	(2)2x14	(2)2x14	3 1/8x7 1/2	4x14	3 1/8x9
12'	3 1/8x9	3 1/8x9	3 1/8x9	3 1/8x10 1/2	3 1/8x10 1/2
14'	3 1/8x10 1/2	3 1/8x10 1/2	3 1/8x10 1/2	3 1/8x12	3 1/8x12
16'	3 1/8x12	3 1/8x12	3 1/8x12	3 1/8x13 1/2	3 1/8x13 1/2
	16'	17'	18'	19'	20'
4'	(2)2x8	(2)2x8	(2)2x8	(2)2x8	(2)2x8
6'	(2)2x10	4x10	4x10	4x10	(2)2x12
8'	4x12	(2)2x14	(2)2x14	(2)2x14	3 1/8x7 1/2
10'	3 1/8x9	3 1/8x9	3 1/8x9	3 1/8x9	3 1/8x10 1/2
12'	3 1/8x10 1/2	3 1/8x10 1/2	3 1/8x10 1/2	3 1/8x12	3 1/8x12
14'	3 1/8x12	3 1/8x12	3 1/8x13 1/2	3 1/8x13 1/2	3 1/8x13 1/2
16'	3 1/8x13 1/2	3 1/8x15	3 1/8x15	3 1/8x15	3 1/8x15
	21'	22'	23'	24'	25'
4'	(2)2x8	(2)2x8	(2)2x8	4x8	4x8
6'	(2)2x12	(2)2x12	(2)2x12	(2)2x12	(2)2x12
8'	4x14	4x14	3 1/8x9	3 1/8x9	3 1/8x9
10'	3 1/8x10 1/2	3 1/8x10 1/2	3 1/8x10 1/2	3 1/8x10 1/2	3 1/8x10 1/2
12'	3 1/8x12	3 1/8x12	3 1/8x12	3 1/8x13 1/2	3 1/8x13 1/2
14'	3 1/8x13 1/2	3 1/8x13 1/2	3 1/8x15	3 1/8x15	3 1/8x15
16'	3 1/8x16 1/2	3 1/8x16 1/2	3 1/8x16 1/2	3 1/8x16 1/2	3 1/8x16 1/2

Minimum Size 6" Headers

[Z]	[A]				
	6'	7'	8'	9'	10'
4'	(3)2x4	(3)2x4	(3)2x4	(3)2x6	(3)2x6
6'	(3)2x6	(3)2x6	(3)2x6	6x6	6x6
8'	6x6	6x6	6x6	(3)2x10	(3)2x10
10'	(3)2x10	(3)2x10	(3)2x10	(3)2x10	(3)2x12
12'	(3)2x10	(3)2x12	(3)2x12	(3)2x12	6x10
14'	(3)2x12	6x10	6x10	(3)2x14	5 1/8x7 1/2
16'	6x10	(3)2x14	5 1/8x7 1/2	6x12	5 1/8x9
	11'	12'	13'	14'	15'
4'	(3)2x6	(3)2x6	(3)2x6	(3)2x6	(3)2x6
6'	6x6	6x6	6x6	6x6	(3)2x8
8'	(3)2x10	(3)2x10	(3)2x10	(3)2x10	6x8
10'	(3)2x12	(3)2x12	(3)2x12	6x10	6x10
12'	(3)2x14	(3)2x14	(3)2x14	5 1/8x7 1/2	5 1/8x7 1/2
14'	5 1/8x7 1/2	5 1/8x9	5 1/8x9	5 1/8x9	5 1/8x9
16'	5 1/8x9	5 1/8x9	5 1/8x10 1/2	5 1/8x10 1/2	5 1/8x10 1/2
	16'	17'	18'	19'	20'
4'	(3)2x6	(3)2x6	(3)2x6	(3)2x6	(3)2x6
6'	(3)2x10	(3)2x10	(3)2x10	(3)2x10	(3)2x10
8'	(3)2x12	(3)2x12	(3)2x12	(3)2x12	(3)2x12
10'	(3)2x14	(3)2x14	(3)2x14	5 1/8x7 1/2	5 1/8x7 1/2
12'	6x12	5 1/8x9	5 1/8x9	5 1/8x9	5 1/8x9
14'	5 1/8x9	5 1/8x10 1/2	5 1/8x10 1/2	5 1/8x10 1/2	5 1/8x10 1/2
16'	5 1/8x10 1/2	5 1/8x12	5 1/8x12	5 1/8x12	5 1/8x12
	21'	22'	23'	24'	25'
4'	6x6	6x6	6x6	6x6	6x6
6'	(3)2x10	(3)2x10	(3)2x10	(3)2x10	(3)2x10
8'	(3)2x12	6x10	6x10	6x10	(3)2x14
10'	5 1/8x7 1/2	6x12	6x12	5 1/8x9	5 1/8x9
12'	5 1/8x9	6x14	5 1/8x10 1/2	5 1/8x10 1/2	5 1/8x10 1/2
14'	5 1/8x10 1/2	5 1/8x12	5 1/8x12	5 1/8x12	5 1/8x12
16'	5 1/8x12	5 1/8x13 1/2	5 1/8x13 1/2	5 1/8x13 1/2	5 1/8x13 1/2

This design may be used at the owners risk as a minimum design in lieu of specific construction plans and engineering design furnished by the owner.

Final approval is subject to field inspection and compliance with all relevant codes, laws and ordinances. Requirements on this handout based on 2015 IRC codes.

20 PSF Snow Load Region

Roof Beams

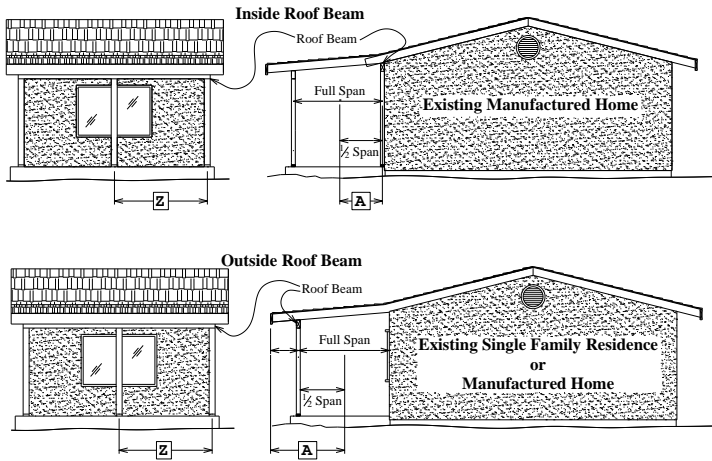

Requirements based on 15psf dead load

Minimum Size 4" Roof Beam

[Z]	[A]				
	6'	7'	8'	9'	10'
4'	4x4	(2)2x6	(2)2x6	(2)2x6	(2)2x6
6'	4x6	(2)2x8	(2)2x8	(2)2x8	(2)2x8
8'	4x8	(2)2x10	(2)2x10	(2)2x10	4x10
10'	(2)2x10	4x10	(2)2x12	(2)2x12	4x12
12'	(2)2x12	4x12	(2)2x14	3 1/8x7 1/2	4x14
14'	(2)2x14	4x14	3 1/8x9	3 1/8x9	3 1/8x10 1/2
16'	3 1/8x9	3 1/8x9	3 1/8x10 1/2	3 1/8x10 1/2	3 1/8x10 1/2

Minimum Size 6" Roof Beam

[Z]	[A]				
	6'	7'	8'	9'	10'
4'	(3)2x4	(3)2x4	(3)2x4	(3)2x6	(3)2x6
6'	(3)2x6	(3)2x6	(3)2x6	6x6	6x6
8'	6x6	6x6	6x6	(3)2x10	(3)2x10
10'	(3)2x10	(3)2x10	(3)2x10	(3)2x10	(3)2x12
12'	(3)2x10	(3)2x12	(3)2x12	(3)2x12	6x10
14'	(3)2x12	6x10	6x10	(3)2x14	5 1/8x7 1/2
16'	6x10	(3)2x14	5 1/8x7 1/2	6x12	5 1/8x9

Floor Beams

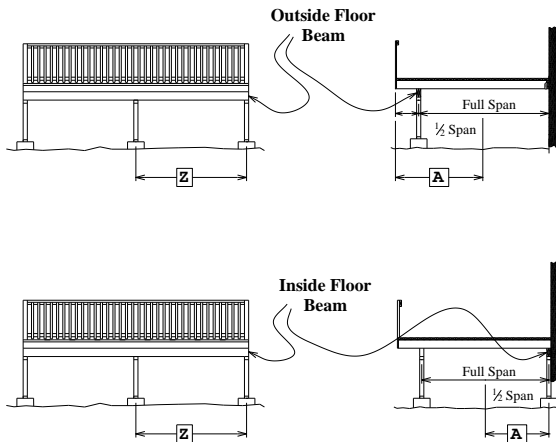

Requirements based on 50psf live load and 10psf dead load

Minimum Size 4" Roof Beam

[Z]	[A]				
	6'	7'	8'	9'	10'
4'	(2)2x6	(2)2x6	4x6	4x6	(2)2x8
6'	(2)2x8	4x8	(2)2x10	(2)2x10	4x10
8'	4x10	(2)2x12	(2)2x12	4x12	(2)2x14
10'	4x12	(2)2x14	4x14	3 1/8x9	3 1/8x9
12'	3 1/8x9	3 1/8x9	3 1/8x10 1/2	3 1/8x10 1/2	3 1/8x10 1/2
14'	3 1/8x10 1/2	3 1/8x10 1/2	3 1/8x12	3 1/8x12	3 1/8x12
16'	3 1/8x12	3 1/8x12	3 1/8x13 1/2	3 1/8x13 1/2	3 1/8x15

Minimum Size 6" Roof Beam

[Z]	[A]				
	6'	7'	8'	9'	10'
4'	(3)2x6	(3)2x6	(3)2x6	(3)2x6	(3)2x6
6'	6x6	6x6	6x6	(3)2x8	(3)2x10
8'	(3)2x10	(3)2x10	(3)2x10	(3)2x12	(3)2x12
10'	(3)2x12	(3)2x12	6x10	6x10	(3)2x14
12'	6x10	(3)2x14	5 1/8x7 1/2	6x12	5 1/8x9
14'	5 1/8x7 1/2	5 1/8x9	5 1/8x9	5 1/8x9	5 1/8x10 1/2
16'	5 1/8x9	5 1/8x9	5 1/8x10 1/2	5 1/8x10 1/2	5 1/8x12

This design may be used at the owners risk as a minimum design in lieu of specific construction plans and engineering design furnished by the owner.

Final approval is subject to field inspection and compliance with all relevant codes, laws and ordinances. Requirements on this handout based on 2015 IRC codes.

20 PSF Snow Load Region

Footings with Floor

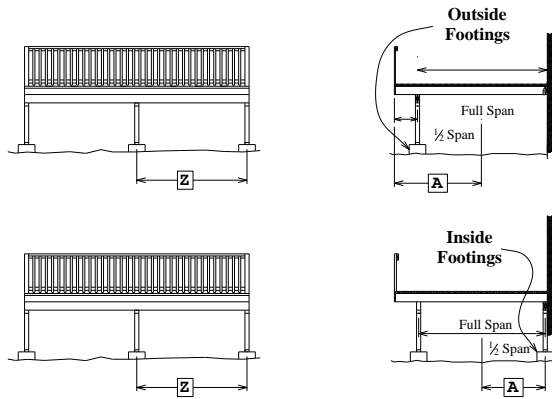

Minimum Size Footing

[Z]	[A]				
	6'	7'	8'	9'	10'
4'	12x12	13x13	14x14	15x15	16x16
6'	15x15	16x16	17x17	18x18	19x19
8'	17x17	18x18	20x20	21x21	22x22
10'	19x19	21x21	22x22	23x23	24x24
12'	21x21	22x22	24x24	25x25	27x27
14'	22x22	24x24	26x26	27x27	29x29
16'	24x24	26x26	28x28	29x29	31x31

Footings with Roof

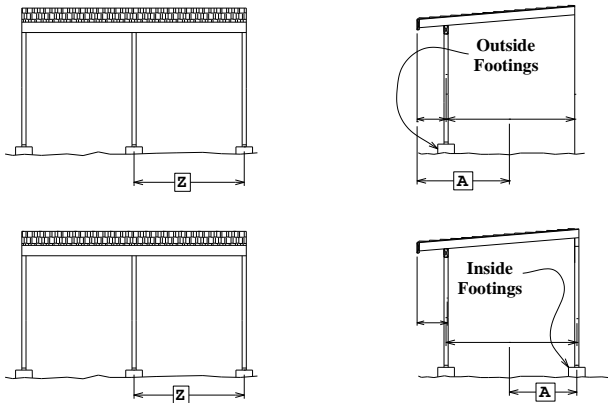

Minimum Size Footing

[Z]	[A]				
	6'	7'	8'	9'	10'
4'	9x9	10x10	11x11	11x11	12x12
6'	11x11	12x12	13x13	14x14	15x15
8'	13x13	14x14	15x15	16x16	17x17
10'	15x15	16x16	17x17	18x18	19x19
12'	16x16	17x17	18x18	20x20	21x21
14'	17x17	19x19	20x20	21x21	22x22
16'	18x18	20x20	21x21	22x22	24x24

Footings with Roof & Floor

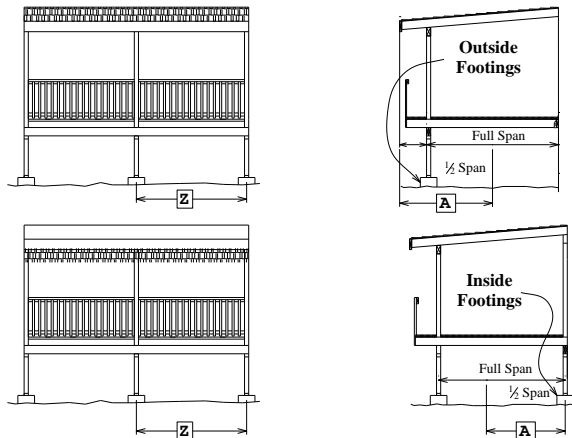

Minimum Size Footing

[Z]	[A]				
	6'	7'	8'	9'	10'
4'	15x15	16x16	18x18	19x19	20x20
6'	19x19	20x20	21x21	23x23	24x24
8'	21x21	23x23	25x25	26x26	28x28
10'	24x24	26x26	28x28	29x29	31x31
12'	26x26	28x28	30x30	32x32	34x34
14'	28x28	30x30	32x32	34x34	36x36
16'	30x30	32x32	35x35	37x37	39x39

General Notes

- Footings are designed to support both the roof and the floor loads
- Span [A] for outside footing must extend out to the largest extension (roof overhang or floor cantilever)
- Posts supporting roof beam MUST rest on posts supporting floor beam

This design may be used at the owners risk as a minimum design in lieu of specific construction plans and engineering design furnished by the owner.

Final approval is subject to field inspection and compliance with all relevant codes, laws and ordinances. Requirements on this handout based on 2015 IRC codes.

20 PSF Snow Load Region

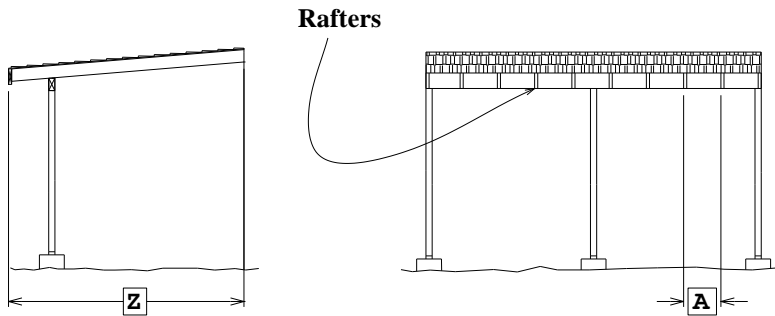

All requirements based on 15psf dead load

Rafter Spans

Minimum Rafter Spacing			
[Z]	[A]		
	12"	16"	24"
4'	2x4	2x4	2x4
6'	2x4	2x4	2x4
8'	2x4	2x4	2x6
10'	2x6	2x6	2x6
12'	2x6	2x8	2x8
14'	2x6	2x8	2x10
16'	2x10	2x10	

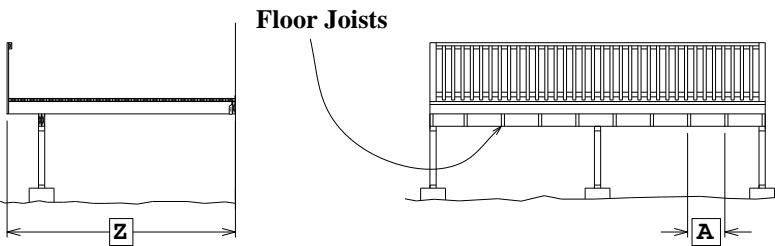

All requirements based on 15psf dead load

Floor Joist Spans

Minimum Joist Spacing			
[Z]	[A]		
	12"	16"	24"
4'	2x6	2x6	2x6
6'	2x6	2x6	2x6
8'	2x6	2x6	2x8
10'	2x6	2x8	2x10
12'	2x8	2x10	2x10
14'	2x10	2x10	2x12
16'	2x10	2x12	

This design may be used at the owners risk as a minimum design in lieu of specific construction plans and engineering design furnished by the owner.

Final approval is subject to field inspection and compliance with all relevant codes, laws and ordinances. Requirements on this handout based on 2015 IRC codes.