

## AMENDED

### AGENDAS

**FOR THE AMARILLO CITY COUNCIL WORK SESSION TO BE HELD ON TUESDAY, JUNE 27, 2017 AT 3:30 P.M. AND THE REGULAR MEETING OF THE AMARILLO CITY COUNCIL AT 5:00 P.M., CITY HALL, 509 SOUTHEAST 7<sup>th</sup> AVENUE, COUNCIL CHAMBER ON THE THIRD FLOOR OF CITY HALL, AMARILLO, TEXAS.**

---

**Please note:** *The City Council may take up items out of the order shown on any Agenda. The City Council reserves the right to discuss all or part of any item in an executive session at any time during a meeting or work session, as necessary and allowed by state law. Votes or final decisions are made only in open Regular or Special meetings, not in either a work session or executive session.*

### WORK SESSION

- A. City Council will discuss or receive reports on the following current matters or projects.
- (1) Review agenda items for regular meeting and attachments;
  - (2) Presentation on advance wastewater treatment process project with Xcel Energy;
  - (3) Report from Local Government Corporation on action taken at the Local Government Corporation meeting on June 26, 2017; and
  - (4) Consider future Agenda items and request reports from City Manager.
- B. City Council may convene in Executive Session to receive reports on or discuss any of the following pending projects or matters:
- (1) Attorney consultation. Consult with the attorney on a matter in which the attorney's duty to the governmental body under the Texas Disciplinary Rules of Professional Conduct conflicts with this chapter, in accordance with the Texas Open Meetings Act, Texas Government Code, Section 551.071.
    - (a) Consultation with attorney regarding status of negotiations – MPEV lease agreement and related matters.

---

### REGULAR MEETING ITEMS

**INVOCATION:** Blake Clevenger, Hillside Christian Church

**PUBLIC COMMENT:** Citizens who desire to address the City Council with regard to matters on the agenda or having to do with the City's policies, programs, or services will be received at this time. The total time allotted for comments is 30-minutes with each speaker limited to three (3) minutes. City Council may not discuss items not on this agenda, but may respond with factual, established policy information, or refer to staff. The City Council may choose to place the item on a future agenda.  
*(Texas Attorney General Opinion. JC-0169.)*

1. **CONSENT AGENDA:**

It is recommended that the following items be approved and that the City Manager be authorized to execute all documents necessary for each transaction:

*THE FOLLOWING ITEMS MAY BE ACTED UPON BY ONE MOTION. NO SEPARATE DISCUSSION OR ACTION ON ANY OF THE ITEMS IS NECESSARY UNLESS DESIRED BY A COUNCILMEMBER, IN WHICH EVENT THE ITEM SHALL BE CONSIDERED IN ITS NORMAL SEQUENCE AFTER THE ITEMS NOT REQUIRING SEPARATE DISCUSSION HAVE BEEN ACTED UPON BY A SINGLE MOTION.*

A. **Minutes:**

Approval of the City Council minutes of the orientation and regular meetings held on June 20, 2017 and the press conference held on June 21, 2017.

- B. Award of Swimming Pools and Zoo Concession Supplies Annual Contract:  
Awarded to: Ben E. Keith -- \$83,176.94  
This award is to approve the annual contract for the purchase of concession supplies used at our Swimming Pools and Zoo for the City of Amarillo.

## REGULAR AGENDA

2. **DISCUSS AND CONSIDER METHODS OF PUBLIC COMMENT AND PUBLIC COMMENT POLICY**
3. **ORDINANCE NO. 7672:**  
This is the second and final reading of an ordinance rezoning of Lots 9 thru 12, Block 1, Wolflin Place Addition Lot 1, Lot 14A, Block 1, Wolflin Place Addition Unit No. 5, and a 0.19 acre tract of unplatted land, all in Section 186, Block 2, AB&M Survey, Potter County, Texas plus one-half of all bounding streets, alleys, and public ways to change from Planned Development District 278, 278A, and Residential District 1 (R-1) to amended Planned Development District 278. (Vicinity of Hughes Street and Wolflin Avenue.)
4. **ORDINANCE NO. 7671:**  
This is the second and final reading of an ordinance amending established parking fees for the parking garage.
5. **RESOLUTION – CONSIDERATION OF RENAMING A SEGMENT OF PINNACLE DRIVE TO WESTOVER PARKWAY:**  
CISD is requesting the City of Amarillo to consider renaming a street segment, which extends for one block east of Coulter Street, a major arterial road, and break in the existing Pinnacle Drive. (Vicinity: A one block segment of Pinnacle Drive between Coulter Street and Paragon Drive.)
6. **RESOLUTION – DENYING SOUTHWESTERN PUBLIC SERVICE COMPANY SURCHARGE:**  
This resolution denies the surcharge related to Docket No. 45524 submitted by Southwestern Public Service Company, authorizing participation in a coalition of similarly situated cities, authorizing participation in related rate proceedings, requiring the reimbursement of municipal rate case expenses, and authorizing the retention of special counsel.
7. **AWARD – BID # 5714 JOB# 560062: ARDEN ROAD STORM SEWER AND PLAYA #7 EXCAVATION – PHASE I:**  
Award to low responsive bidder – Williams Ditching, LLC -- \$ 2,418,171.41  
This item is to approve the contract for the Arden Road Storm Sewer and Playa #7 Excavation – Phase I. This proposed project will consist of the installation of storm sewer in future Arden Road to serve the adjacent subdivisions. The storm sewer will cross Loop 335 (Soncy Road) and discharge into Playa #7 (Greenways Playa) which will be excavated as part of this project to allow the storm sewer to discharge. The installation will include repair of pavement in Loop 335 where the storm sewer line is crossing the road.
8. **APPROVAL -- WINSTEAD LEASE EXTENSION:**  
This item discusses and considers action to approve and extend Engagement of Winstead PC to assist in negotiation of long term lease agreement and related matters with affiliated Minor League Baseball team.
9. **AWARD – BID # 5761 JOB # 430036 LANDFILL GAS COLLECTION AND CONTROL SYSTEM – PHASE I:**  
Award to Landmarc Environmental Systems, LLC -- \$3,993,577.00  
This item is to approve the contract for Solid Waste Improvements for the construction of a landfill gas collection and control system at the City of Amarillo landfill.

10. **APPROVAL -- STATE OF TEXAS, DEPARTMENT OF TRANSPORTATION  
RAMP GRANT APPLICATION, TXDOT CSJ NO.: 42M1704AMRI, RICK  
HUSBAND AMARILLO INTERNATIONAL AIRPORT:**

This item approves a Routine Airport Maintenance Program (RAMP) Grant Application from TxDOT. This Grant matches funds up to \$50,000 for the general approved maintenance at non-hub primary airports.

**MISCELLANEOUS**

1. Boards and Commission – needed appointments as listed on attached.

Amarillo City Hall is accessible to individuals with disabilities through its main entry on the south side (Southeast 7<sup>th</sup> Avenue) of the building. An access ramp leading to the main entry is located at the southwest corner of the building. Parking spaces for individuals with disabilities are available in the south parking lot. City Hall is equipped with restroom facilities, communications equipment and elevators that are accessible. Individuals with disabilities who require special accommodations or a sign language interpreter must contact the City Secretary's Office 48 hours prior to meeting time by telephoning 378-3013 or the City TDD number at 378-4229.

Posted this 23rd day of June 2017.

Amarillo City Council meetings stream live on Cable Channel 110 and are available online at:

[www.amarillo.gov/granicus](http://www.amarillo.gov/granicus)

*Archived meetings are also available.*

A



STATE OF TEXAS  
COUNTIES OF POTTER  
AND RANDALL  
CITY OF AMARILLO

On the 20th day of June 2017, the Amarillo City Council met at 1:00 p.m. for City Council Orientation located at Osage Water Treatment Plant, 3701 South Osage Street, with the following members present:

- |               |                     |
|---------------|---------------------|
| GINGER NELSON | MAYOR               |
| ELAINE HAYS   | COUNCILMEMBER NO. 1 |
| FREDA POWELL  | COUNCILMEMBER NO. 2 |
| EDDY SAUER    | COUNCILMEMBER NO. 3 |
| HOWARD SMITH  | COUNCILMEMBER NO. 4 |

Absent were none. Also in attendance were the following administrative officials:

- |                 |                        |
|-----------------|------------------------|
| JARED H. MILLER | CITY MANAGER           |
| BOB COWELL      | DEPUTY CITY MANAGER    |
| KEVIN STARBUCK  | ASSISTANT CITY MANAGER |
| FRANCES HIBBS   | CITY SECRETARY         |

A presentation was presented by Russell Grubbs, Director of Utilities followed by a tour of the Osage Water Treatment Plant.

Mayor Nelson advised that the meeting was adjourned.

ATTEST:

\_\_\_\_\_  
Frances Hibbs, City Secretary

\_\_\_\_\_  
Ginger Nelson, Mayor

STATE OF TEXAS  
COUNTIES OF POTTER  
AND RANDALL  
CITY OF AMARILLO

On the 20th day of June 2017, the Amarillo City Council met at 3:30 p.m. for a work session, and the regular session was held at 5:00 p.m. in the Council Chamber located on the third floor of City Hall at 509 Southeast 7th Avenue, with the following members present:

GINGER NELSON  
ELAINE HAYS  
FREDA POWELL  
EDDY SAUER  
HOWARD SMITH

MAYOR  
COUNCILMEMBER NO. 1  
COUNCILMEMBER NO. 2  
COUNCILMEMBER NO. 3  
COUNCILMEMBER NO. 4

Absent were none. Also in attendance were the following administrative officials:

JARED H. MILLER  
BOB COWELL  
MICK MCKAMIE  
BLAIR SNOW  
FRANCES HIBBS

CITY MANAGER  
DEPUTY CITY MANAGER  
CITY ATTORNEY  
MGMT. ANALYST PUBLIC SAFETY  
CITY SECRETARY

The invocation was given by Dr. Burt Palmer, Polk Street United Methodist Church. Mayor Nelson led the audience in the Pledge of Allegiance.

Mayor Nelson established a quorum, called the meeting to order, welcomed those in attendance and the following items of business were conducted:

**PUBLIC COMMENT:**

Jesse Pfrimmer, 5723 South Milam Street, presented 17-years of expenses for water. He stated he was frustrated at the current water conservation. He further stated the need for the City to address bicycling activities in our City. Rupert C. Brashears, Jr., 2422 Poplar Street, he stated he spoke to the Texas Court of Appeals and inquired if his constitutional right was violated according to the 13<sup>th</sup> Amendment. James Schenck, 6216 Gainsborough Street, asked Council to allow the public to speak on various agenda items as they are presented. He further inquired about Type A and B Economic Development Corporations. Edith DiTommaso, 1613 Bowie Street, #B, stated she was thankful for the Activity Center activity on the agenda. She further stated she wished Senate Bill 4 had not passed. Kit Rudd, 6850 Grande, stated he has been living on the street this week with the homeless. He stated the problems with the homeless have increased over last year. He further stated he would begin his tiny house project soon. There were no further comments.

**ITEM 1:** Mayor Nelson presented the consent agenda and asked if any item should be removed for discussion or separate consideration. Motion was made by Councilmember Sauer to approval of the consent agenda, seconded by Councilmember Powell.

A. **Minutes:**

Approval of the City Council minutes of the orientation and regular meetings held on June 13, 2017.

Voting AYE were Mayor Nelson, Councilmembers Hays, Powell, Sauer and Smith; voting NO were none; the motion carried by a 5:0 vote of the Council.

**REGULAR AGENDA**

These items were taken out of order:

**ITEM 5:** Mayor Nelson presented a resolution discussing and considering all matters incident and related to approving the resolution of the Amarillo Economic Development Corporation authorizing the issuance of the "Amarillo Economic Development Corporation Taxable Sales Tax Revenue Refunding Bonds, Series 2017," including the

adoption of a resolution pertaining thereto. This item was presented by Steven Adams, Specialized Public Finance, Inc. Motion was made by Councilmember Hays, seconded by Councilmember Smith, that the following captioned resolution be passed:

**RESOLUTION NO. 06-20-17-1**

**A RESOLUTION OF THE CITY COUNCIL OF THE CITY OF AMARILLO, TEXAS, RELATING TO THE "AMARILLO ECONOMIC DEVELOPMENT CORPORATION TAXABLE SALES TAX REVENUE REFUNDING BONDS, SERIES 2017"; APPROVING THE RESOLUTION OF THE BOARD OF DIRECTORS OF THE AMARILLO ECONOMIC DEVELOPMENT CORPORATION AUTHORIZING THE ISSUANCE OF SUCH BONDS AND RESOLVING OTHER MATTERS INCIDENT AND RELATED TO THE ISSUANCE OF SUCH BONDS; AND PROVIDING AN EFFECTIVE DATE.**

Voting AYE were Mayor Nelson, Councilmembers Hays, Powell, Sauer and Smith; voting NO were none; the motion carried by a 5:0 vote of the Council.

**ITEM 8:** Chief Ed Drain, Amarillo Police Department presented key provisions and implications of Senate Bill 4 that prohibits or limits the enforcement of immigration laws.

**ITEM 2:** Mayor Nelson presented the first reading of an ordinance rezoning of Lots 9 thru 12, Block 1, Wolflin Place Addition Lot 1, Lot 14A, Block 1, Wolflin Place Addition Unit No. 5, and a 0.19 acre tract of unplatted land, all in Section 186, Block 2, AB&M Survey, Potter County, Texas plus one-half of all bounding streets, alleys, and public ways to change from Planned Development District 278, 278A, and Residential District 1 (R-1) to amended Planned Development District 278. (Vicinity of Hughes Street and Wolflin Avenue.) This item was presented by David Soto, Planner 1. Motion was made by Councilmember Sauer, seconded by Councilmember Powell, that the following captioned ordinance be passed on first reading:

**ORDINANCE NO. 7672**

**AN ORDINANCE OF THE CITY OF AMARILLO, TEXAS: PROVIDING FOR SPECIFIED CHANGES IN THE OFFICIAL ZONING MAP OF THE CITY OF AMARILLO, TEXAS; PROVIDING FOR CHANGE OF THE ZONING AND CLASSIFICATION OF THE FOLLOWING PROPERTY, TO WIT: BEING LOT 14, BLOCK 1 WOLFLIN PLACE ADDITION UNIT NO. 4, A 0.19 ACRE TRACT OF LAND, AND LOTS 9 THRU 12, BLOCK 1, WOLFLIN PLACE ADDITION, ALL IN SECTION 186, BLOCK 2, AB&M SURVEY, POTTER COUNTY, TEXAS, PLUS ONE-HALF OF ALL BOUNDING STREETS, ALLEYS, AND PUBLIC WAYS TO CHANGE FROM PLANNED DEVELOPMENT (PD) DISTRICT 278, PLANNED DEVELOPMENT(PD) DISTRICT 278A, AND RESIDENTIAL DISTRICT 1 (R-1) TO AMENDED PLANNED DEVELOPMENT (PD) DISTRICT 278; PROVIDING FOR SEVERABILITY CLAUSE; PROVIDING A PENALTY CLAUSE; PROVIDING A REPEALER CLAUSE; AND PROVIDING AN EFFECTIVE DATE.**

Voting AYE were Mayor Nelson, Councilmembers Hays, Powell, Sauer and Smith; voting NO were none; the motion carried by a 5:0 vote of the Council.

**ITEM 3:** Mayor Nelson presented the first reading of an ordinance amending established parking fees for the parking garage. This item was presented by Bob Cowell, Deputy City Manager. Councilmember Hays inquired about a pro forma for parking fees. Motion was made by Councilmember Smith, seconded by Councilmember Powell, that the following captioned ordinance be passed on first reading:

**ORDINANCE NO. 7671**

**AN ORDINANCE OF THE CITY COUNCIL OF THE CITY OF AMARILLO: REGULATING PARKING WITHIN THE DOWNTOWN PARKING GARAGE; AMENDING PARKING FEES; PROVIDING SEVERABILITY CLAUSE; PROVIDING A REPEALER CLAUSE; PROVIDING FOR CRIMINAL PENALTY; PROVIDING FOR PUBLICATION AND EFFECTIVE DATE.**

Voting AYE were Mayor Nelson, Councilmembers Hays, Powell, Sauer and Smith; voting NO were none; the motion carried by a 5:0 vote of the Council.

ITEM 4: Mayor Nelson presented the second and final reading on an ordinance amending Amarillo Municipal Code, Chapter 8-2 – Animals and Fowl, to establish a rooster to hen ratio/percentage while exempting governmental entities and non-profits and prohibit the use of traps that injure or maim animals, establishes timeframes for traps to be checked, and ensures the humane treatment of trapped animals. Motion was made by Councilmember Hays, seconded by Councilmember Powell, that the following captioned ordinance be passed on second and final reading:

**ORDINANCE NO. 7670**

**AN ORDINANCE OF THE CITY COUNCIL OF THE CITY OF AMARILLO, TEXAS: AMENDING THE AMARILLO MUNICIPAL CODE, CHAPTER 8-2, PROVIDING FOR DEFINITIONS; ADDING REQUIREMENTS FOR FLOCKS; PROVIDING REQUIREMENTS FOR SETTING TRAPS; PROVIDING FOR SEVERABILITY; PROVIDING FOR REPEALER; PROVIDING FOR CONTINUATION OF PRIOR LAW; PROVIDING PENALTY; PROVIDING FOR PUBLICATION AND EFFECTIVE DATE.**

Voting AYE were Mayor Nelson, Councilmembers Hays, Powell, Sauer and Smith; voting NO were none; the motion carried by a 5:0 vote of the Council.

ITEM 6: Mayor Nelson presented a resolution considering extending the Environmental Task Force Committee which was established by Resolution No. 07-12-16-3. It was charged with researching and evaluating recycling operations for the community and to identify a potential list of other environmental concerns that may be similarly researched and evaluated and brought to the City's attention. The Environmental Task Force is scheduled to sunset July 11, 2017, the committee is requesting extension of time to further accomplish the intended resolution goals. Cole Camp, Chairman of Environmental Task Force Committee, presented this item. Motion was made by Councilmember Sauer, seconded by Councilmember Smith, that the following captioned resolution be passed:

**RESOLUTION NO. 06-20-17-2**

**A RESOLUTION OF THE AMARILLO CITY COUNCIL REAUTHORIZING AND APPOINTING AN ENVIRONMENTAL TASK FORCE; DEFINING ITS PURPOSE, ESTABLISHING GUIDELINES FOR APPOINTMENTS TO THE TASK FORCE; PROVIDING FOR THE TASK FORCE'S DUTIES AND RESPONSIBILITIES; PROVIDING A SUNSET DATE; PROVIDING SEVERABILITY CLAUSE; PROVIDING SAVINGS CLAUSE AND EFFECTIVE DATE.**

Voting AYE were Mayor Nelson, Councilmembers Hays, Powell, Sauer and Smith; voting NO were none; the motion carried by a 5:0 vote of the Council.

ITEM 7: Mayor Nelson presented an item recommending the Construction Contract for the C.E. Warford Activity Center Addition and Remodel at 1330 Northwest 18th Avenue be awarded to Panhandle Steel Building Inc. in the Amount of \$1,241,724.00. This item was presented by Jerry Danforth, Facilities and Special Projects Administrator and Rod Tweet, Parks and Recreation Director. Motion was made by Councilmember Powell, seconded by Councilmember Smith, that this item be approved.

Voting AYE were Mayor Nelson, Councilmembers Hays, Powell, Sauer and Smith; voting NO were none; the motion carried by a 5:0 vote of the Council.

Mayor Nelson advised that the meeting was adjourned.

ATTEST:

---

Frances Hibbs, City Secretary

---

Ginger Nelson, Mayor

STATE OF TEXAS  
COUNTIES OF POTTER  
AND RANDALL  
CITY OF AMARILLO

On the 21st day of June 2017, the Amarillo City Council met at 11:15 a.m. for a Press Conference for an update on the Amarillo Multi-Purpose Event Venue (MPEV) at the Xcel Energy Offices located at 790 South Buchanan Street, with the following members present:

GINGER NELSON  
ELAINE HAYS  
FREDA POWELL  
EDDY SAUER  
HOWARD SMITH

MAYOR  
COUNCILMEMBER NO. 1  
COUNCILMEMBER NO. 2  
COUNCILMEMBER NO. 3  
COUNCILMEMBER NO. 4

Absent were none. Also in attendance were the following administrative officials:

JARED H. MILLER  
BOB COWELL  
MICHELLE BONNER  
KEVIN STARBUCK  
MICK MCKAMIE  
BRYAN MCWILLIAMS  
COURTNEY WHITE  
FRANCES HIBBS

CITY MANAGER  
DEPUTY CITY MANAGER  
ASSISTANT CITY MANAGER  
ASSISTANT CITY MANAGER  
CITY ATTORNEY  
DEPUTY CITY ATTORNEY  
ASSISTANT CITY ATTORNEY  
CITY SECRETARY

Mayor Nelson introduced D.G. Elmore, Elmore Sports Group. Mr. Elmore announced the San Antonio Missions of the Texas League would be the baseball team in the Multi-Purpose Event Venue.

Mayor Nelson advised that the meeting was adjourned.

ATTEST:

---

Frances Hibbs, City Secretary

---

Ginger Nelson, Mayor





# Amarillo City Council Agenda Transmittal Memo



<b>Meeting Date</b>	June 27, 2017	<b>Council Priority</b>	N/A
---------------------	---------------	-------------------------	-----

<b>Department</b>	Parks and Recreation
-------------------	----------------------

### Agenda Caption

Award of Swimming Pools and Zoo Concession Supplies Annual Contract  
Ben E Keith - \$83,176.94

This award is to approve the annual contract for the purchase of concession supplies used at our Swimming Pools and Zoo for the City of Amarillo.

### Agenda Item Summary

Award of annual contract for concession supplies used by Zoo Maintenance and Aquatics.

### Requested Action

Consider approval and award for the City annual contract for concession supplies.

### Funding Summary

Funding for this award is available in the Zoo Trust Fund Operating Concession account 71200.51210 and the Pool Operating Concession account 1840.51210

### Community Engagement Summary

N/A

### Staff Recommendation

City staff is recommending approval and award of the contract.

Bid No. 5755 SWIMMING POOLS AND ZOO CONCESSIONS  
 Opened 4:00 p.m. May 18, 2017

To be awarded as one lot	BEN E KEITH	AFFILIATED FOOD SERVICE
Line 1 Food distribution services chili and cheese to all the pools, per specifications 1 ea		
Unit Price	\$22,309.390	\$32,222.170
Extended Price	22,309.39	32,222.17
Line 2 Food distribution services, for food services products and supplies to the Amarillo zoo, per specifications 1 ea		
Unit Price	\$60,867.560	\$40,666.750
Extended Price	60,867.56	40,666.75
Bid Total	83,176.95	72,888.92

DID NOT MEET SPECS

Award by Vendor 83,176.95



# Amarillo City Council Agenda Transmittal Memo



<b>Meeting Date</b>	June 27, 2017	<b>Council Priority</b>	Community Appearance
---------------------	---------------	-------------------------	----------------------

<b>Department</b>	Planning Department
-------------------	---------------------

### Agenda Caption

Vicinity: Hughes St. & Wolflin Ave.

Rezoning of Lots 9 thru 12, Block 1, Wolflin Place Addition Lot 1, Lot 14A, Block 1, Wolflin Place Addition Unit No. 5, and a 0.19 acre tract of unplatted land, all in Section 186, Block 2, AB&M Survey, Potter County, Texas plus one-half of all bounding streets, alleys, and public ways to change from Planned Development District 278, 278A, and Residential District 1 (R-1) to amended Planned Development District 278

### Agenda Item Summary

This tract of land was zoned Planned Development District 278 in August of 2000 for an office building. By January of 2007, an amendment was made for the expansion of the existing office. This request would unify the existing PD amendments to one consistent PD zoning district. In order to avoid multiple amendments, the Planning Department took this opportunity to clean up these previous approvals and compose one single, organized and easily reviewable ordinance which addresses all previous approvals and this proposed amendment.

Staff's analysis of zoning change requests begins with referring to the Comprehensive Plan's Future Land Use and Character Map in order to identify what it recommends for future land uses. Staff also considers how any zoning change would impact the Comprehensive Plan's recommended Neighborhood Unit Concept (NUC) of development whereby non-residential land uses are encouraged at section-line arterial intersections with a transition to residential uses as development occurs away and inward from the arterial intersections. Staff also considers the principles and recommendations laid out within the Comprehensive Plan, as well existing zoning and development patterns in the area.

During the site visit, Planning Department staff noticed conditions in the area. North and west of this property are developed with commercial uses, such as Wolflin Elementary School and an office. The proposed rezoning lots are located in the Wolflin Place Subdivision. This particular subdivision was approved and platted in 1926 and was originally developed with residential uses. However, since initial development, this immediate area has transitioned into one that is more commercial than residential in nature, through further south, the traditional neighborhood patterns remains in place.

This rezoning request is inconsistent with the adopted 2010 Comprehensive Future Land Use and Character Map element, which designates this area for a future "Neighborhood Conservation" land use. However, the Comprehensive Plan document itself states (Pg 2.13) that customized zoning (which a PD is) may provide for small-scale office or retail uses on vacant sites at the edge of the neighborhood or other appropriate locations. This request is therefore consistent with elements of the plan as adopted.

The Neighborhood Unit Concept is also a key piece of the adopted plan, in which zoning transitions from

# Amarillo City Council

## Agenda Transmittal Memo



---

areas of lower density at section corners to areas of high density. This concept of development ensures that commercial areas will have less of an impact to residential areas. This concept does not affect or compromise the Neighborhood Unit Concept as this request acts as a transition between the commercial activities to residential area. The established commercial activity has previously occurred near the intersection of Wolflin Ave & Washington St.

Measures for protecting the nearby residential neighborhoods are important. A screening fence is required between the rear and side lot lines between the commercial use and residential use, for just this purpose. The applicant is also screening the parking lot from the front view as well, though not required. These adequate safeguards are in place to mitigate any negative impacts to the residences nearby. Per Section 4-10-104 of the Zoning Ordinance, a site plan shall be approved and filed as part of the Planned Development ordinance, meaning the approval of the PD ordinance shall constitute approval of the associated site plan as well.

In summary, the application is consistent with elements of the Comprehensive Plan as well as with the zoning & development patterns of the area, making this request appropriate.

---

### Requested Action

The applicant is requesting the rezoning of lots 9 thru 12, previously zoned Residential District 1 (R-1), to change to Planned Development, in order to develop and expand the parking lot for the commercial property to the north.

---

### Funding Summary

N/A

---

### Community Engagement Summary

The item was distributed to all applicable internal and external entities. Notices have been sent out to 15 property owners within 200 feet regarding this proposed rezoning. At the time of this writing, the Planning Department has received no comments regarding this request.

The item was recommended for approval by 6:0 vote of the Planning and Zoning Commission at its June 20, 2017 public meeting.

---

### City Manager Recommendation

Planning Staff has reviewed the associated ordinance and exhibit and recommends the City Council approve the item as submitted.

---

ORDINANCE NO. 7672

AN ORDINANCE OF THE CITY OF AMARILLO, TEXAS: PROVIDING FOR SPECIFIED CHANGES IN THE OFFICIAL ZONING MAP OF THE CITY OF AMARILLO, TEXAS; PROVIDING FOR CHANGE OF THE ZONING AND CLASSIFICATION OF THE FOLLOWING PROPERTY, TO WIT: **BEING LOT 14, BLOCK 1 WOLFLIN PLACE ADDITION UNIT NO. 4, A 0.19 ACRE TRACT OF LAND, AND LOTS 9 THRU 12, BLOCK 1, WOLFLIN PLACE ADDITION, ALL IN SECTION 186, BLOCK 2, AB&M SURVEY, POTTER COUNTY, TEXAS, PLUS ONE-HALF OF ALL BOUNDING STREETS, ALLEYS, AND PUBLIC WAYS TO CHANGE FROM PLANNED DEVELOPMENT (PD) DISTRICT 278, PLANNED DEVELOPMENT(PD) DISTRICT 278A, AND RESIDENTIAL DISTRICT 1 (R-1) TO AMENDED PLANNED DEVELOPMENT (PD) DISTRICT 278;** PROVIDING FOR SEVERABILITY CLAUSE; PROVIDING A PENALTY CLAUSE; PROVIDING A REPEALER CLAUSE; AND PROVIDING AN EFFECTIVE DATE.

---

WHEREAS, the Planning & Zoning Commission for the City of Amarillo and the governing body for the City of Amarillo, in compliance with the charter and the state law with reference to zoning regulations and a zoning map, have given requisite notice by publication and otherwise, and after holding hearings and affording a full and fair hearing to all property owners and persons interested, generally, and to persons situated in the affected area and in the vicinity thereof, is of the opinion that zoning changes should be made as set out herein; and,

WHEREAS, the City Council has considered the final recommendation and report of the Planning & Zoning Commission and has held public hearings on such proposed zoning changes, all as required by law;

NOW, THEREFORE, BE IT ORDAINED BY THE CITY COUNCIL OF THE CITY OF AMARILLO, TEXAS:

SECTION 1: That the basic Zoning Ordinance for the City of Amarillo, as enacted by the governing body for the City of Amarillo on August 12, 2014 and included within Chapter 4-10 of the Code of Ordinances for the City of Amarillo, is hereby amended insofar as the property hereinafter set forth, and said ordinance and the zoning map shall be amended insofar as the property hereinafter described, being Wolflin Place Addition, Unit No. 4, Block 1, Lot 14, a 0.19 acre tract of land, and Wolflin Place Addition, Unit No. 4, Block 1, Lots 9-12, all within AB&M Survey, Section 186, Block 2, Potter County, Texas, a zone change from a combination of Office District 2 (O-2), General Retail (GR), Residential District 3, (R-3) Planned Development (PD) District 278 (*adopted the 29<sup>th</sup> day of August, 2000*), and Amendment to Planned Development (PD) District 278 (PD-278A) (*adopted the 2<sup>nd</sup> day of January 2007*) zoning districts shall henceforth be permanently zoned as Planned Development (PD) District 278, for one expanded office building (see Exhibit 1). The Director of Planning is hereby directed to

correct zoning district maps in the office of the Director of Planning, to reflect the herein described changes in zoning.

SECTION 2. That in all other respects, the use of the hereinabove described property shall be subject to all applicable regulations contained in Chapter 4-10 of the Code of Ordinances for the City of Amarillo, as amended.

SECTION 3. Repealer. All ordinances and resolutions or parts thereof that conflict with this ordinance are hereby repealed, to the extent of such conflict.

SECTION 4. Severability. The terms and provisions of this Ordinance shall be deemed to be severable in that, if any portion of this Ordinance shall be declared to be invalid, the same shall not affect the validity of the other provisions of this Ordinance.

SECTION 5. Penalty. Any person who violates any provisions of this article shall be guilty of a misdemeanor and, upon conviction, shall be subject to a fine as provided for in Section 4-10-4 of the Code of Ordinances for the City of Amarillo. Each day of such violation shall constitute a separate offense.

SECTION 6. Allowed Uses. The underlying zoning district for this Planned Development will be to Office 1 Zoning District in order to ensure consistent treatment of the site. However, uses still must be approved specific to the placement illustrated in the referenced exhibits. Any future construction must be addressed and approved with a new exhibit.

A. 1 Office building. Only on specified site location as illustrated in "Exhibit 2".

SECTION 7. Development Standards. That the development standards for the Planned Development such as: lot areas, lot widths, lot depths, front yard, side yard, rear yard, lot coverage, as well as height, parking, off-street loading requirements, and landscaping, shall conform to the following:

A. "Exhibit 1" site location:

1. Maximum building height: 1 story
2. Lot Coverage: 33.4% ( an increase of 3.7% from the original PD)
3. 48 total parking spaces ( an increase of 15 spaces from the original PD)
4. 27.9 percent of landscaping groundcover with 22 trees.

The overall core development standards for the entire planned development will be as follows:

B. "Exhibit 2" site location:

1. Maximum building height: 1 story
2. **Lot Coverage: 33.4% (remained the same)**
3. 143 total parking spaces ( addition of 62)
4. 26.10% percent of landscaping groundcover with 22 trees (addition of 7).

**SECTION 8.** Parking and driveways. All parking and driveways shall conform to the requirements of the Zoning Ordinance and the Parking and Driveway Manual of the City of Amarillo.

**SECTION 9.** Exterior Lighting. All exterior lighting shall be directed onto properties in such a manner as to prohibit glare across property lines, and that minimizes or eliminates glare onto adjacent properties. Lighting will be directed from soffits and stone columns. Landscaping lighting will originate from low voltage ground lights and up lights on trees.

**SECTION 10.** Signage. All signage shall conform to the following:

- A. All signs shall conform to the requirements of the Office District 1 (O-1) zoning district as specified in Chapter 4-2 of the Amarillo Code of Ordinances. No sign shall be constructed so to contain, include, or be illuminated by any flashing, rotating, moving, or intermittent light source or reflector. No portable signs shall also be allowed within this Planned Development.
- B. All existing signs made non-conforming by this Planned Development shall continue to be allowed until abated for more than ninety (90) days, at which time, the "O-1" Office District 1 sign requirements shall be enforced.

**SECTION 11.** Future development. The development of any future land use which would not be allowed by this Planned Development shall require an application for amendment to PD 278. Any Planned Development amendment shall conform to all Planned Development requirements as specified by Chapter 4-10 Zoning Ordinance for the City of Amarillo. Any additional uses or buildings planned to be added also shall require an application for amendment to PD 278 , accompanied by an updated site plan.

**SECTION 12.** Publishing and Effective Date. This ordinance shall be published and become effective according to law.

INTRODUCED AND PASSED by the City Council of the City of Amarillo, Texas, on First Reading on this the 20th day of June, 2017 and PASSED on Second and Final Reading on this the 27th day of June, 2017.

\_\_\_\_\_  
Ginger Nelson, Mayor

ATTEST:

\_\_\_\_\_  
Frances Hibbs, City Secretary

APPROVED AS TO FORM:

\_\_\_\_\_  
William M. McKamie, City Attorney

Ordinance No. \_\_\_\_\_

# EXHIBIT 1

Planned Development District 278



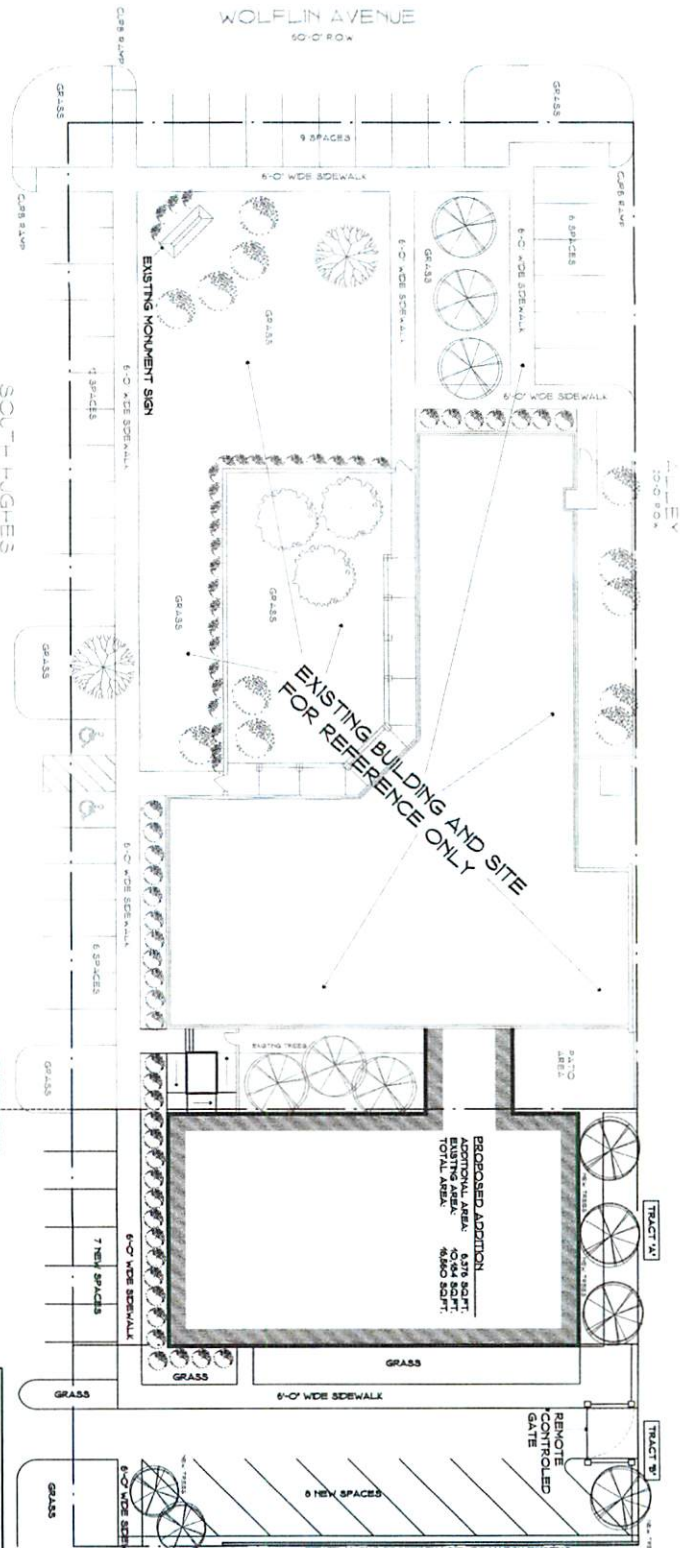

**SITE PLAN**

**SITE PLAN NOTES:**

**SITE DATA:**

TRACT #1, 2025 HUGHES SECTION 04, A3 & H SURVEY LOT BLOCK 0002, RESERVING 27'8" & 3' X 20' W/4' OF THE CORNER OF SECTION 04, BLOCK 0002 (OTHER CORNER), TRACT #1, BLOCK 0002, HUGHES VOLUNTARY PLACE, LOT 002 BLOCK 0002, AMARILLO (OTHER CORNER), TRACT #1

PURPOSE OF DEVELOPMENT: ADDITION TO OFFICE BUILDING

DEVELOPER: LATHAM & COMPANY, INC. (LATHAM)

AMARILLO, TEXAS 79001

PROJECT NO. 2025-001

EXISTING ZONING: TRACT #1, RESIDENTIAL

PROPOSED ZONING: PLANNED DEVELOPMENT FOR AN ADDITION

NEW TOTAL # PARKING SPACES: 48 (27 EXISTING & 21 NEW)

TOTAL AREA OF PROJECT: 41,652 SQ FEET (21,000 ± PAVED & 20,652 ± UNPAVED)

PERCENT OF BUILDING LOT COVERAGE: 34.4% (31,762 SQ FT)

MAXIMUM BUILDING HEIGHT: ONE (1) STORY

NUMBER OF EMPLOYEES: 50 FULL TIME

HOURS AND DAYS OF OPERATION: 8 AM TO 5 PM MONDAY THRU FRIDAY

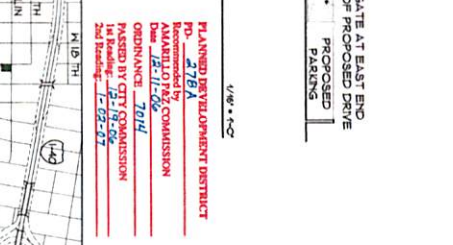
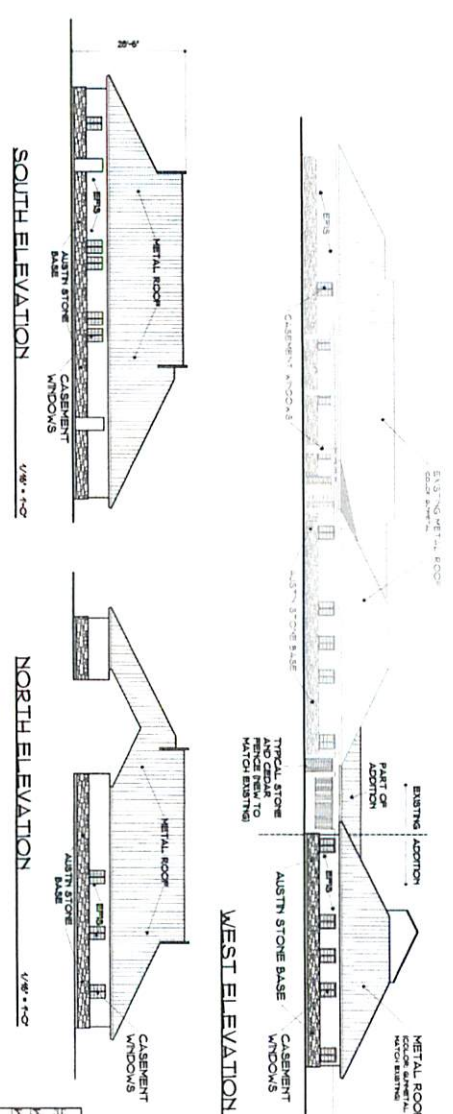

**PLANNED DEVELOPMENT DISTRICT**

PD - 278A

Recommended by AMARILLO CITY COMMISSION

ORDINANCE 7014

PASSED BY CITY COMMISSION

1st Reading: 12-18-06

2nd Reading: 12-02-07

**PROJECT LOCATION**

HUGHES

WOLFLIN

HAYDEN

WASHINGTON

AMARILLO COLLEGE

120 TH

124 TH

126 TH

125 TH

**PROJECT NO.** 2025-001

**DATE:** 12-08-06

**NAME OF DEVELOPER:** Latham & Company, Inc.

**WD ARCHITECTS**

613 S. CENTRO, #606

AMARILLO, TEXAS

**PERSONS:**

DATE: 12-08-06

SHEET NO. 1

**An Addition to an Existing Building for**

**LATHAM & COMPANY, INC.**

2025 S. HUGHES

AMARILLO, TEXAS

REGISTERED ARCHITECT

STATE OF TEXAS

Ordinance No. \_\_\_\_\_

# EXHIBIT 2

Planned Development District 278

### Site Data:

Legal Description: Lots 9, 10, & 11 of Wolflin Place Amended, an addition to the City of Amarillo, Potter County, Texas, according to the recorded map or plat thereof, or recorded in Volume 134, Page 21 of the Deed Records of Potter County, Texas.

Purpose of development: Off-street Parking - 62 spaces

Developer: Atebury Elevators, LLC.  
3905 Bell  
Amarillo, TX. 79109 - ph. (806)353-6671.

Landowner: Atebury Elevators, LLC.  
3905 South Bell  
Amarillo, TX. 79109 - ph. (806)353-6671.

Developer agent: Turner LandArchitecture LLC.  
905 South Fillmore, Suite 702  
Amarillo, TX. 79101 - ph. (806)342-9400.

Existing zoning classification: Residential

Requested zoning classification: Planned Development

Total area of property in acres and square feet: 48 acres / 20,925 sq. ft.

Percent of maximum lot coverage: 19%

Percent of on-site landscaping: 12%

Number of employees: 50

Hours and days of operation: Monday-Friday, 8:00am-5:00pm

### Site Plan Notes:

All parking is currently off street and shall remain. New parking to the south will be off-street. Parking spaces (including handicapped) shall conform to the requirements of the Driveway & Parking Manual of the City of Amarillo.  
All exterior lighting shall be directed onto the property in a manner to minimize or eliminate the glare across adjacent property lines. Parking lot lighting will be from low light poles.  
No signs will be operated on the property that use or have attached any rotating, flashing, or pulsating lighting source or reflector. No portable signs will be allowed.  
Any and all utility relocations or adjustments required for this development shall be the responsibility of the developer.  
All fencing, screening, landscaping, driveways and parking areas shall be maintained in good condition at all times by the owner. All landscaping to be totally installed once the parking lot has been constructed, or within six months of occupying parking lot if bare weather exists. All landscape materials, trees, shrubs, and plants shall be installed in a manner as depicted on this site plan.  
All landscaped areas shall be served with a sprinkler system.  
The approval of this development by the City of Amarillo in no way shall alter or abrogate requirements of the Uniform Building Code as adopted and amended by the City of Amarillo.  
All light poles, shrubbery and trees located in the street or on public utility easements are subject to removal if they hinder repair or new construction of utility equipment. The City of Amarillo and their franchised companies shall not be held liable for the replacement cost of such items destroyed or damaged due to construction or repair of utility equipment.  
All new trees shown on the site plan to be at least 6'-0" in height.

Any additional bulk or area requirements not specifically noted on this site plan shall comply with the zoning district in which the property was located prior to this amendment.  
No use other than that allowed under the previous zoning classification or that which is specified by this site plan is allowed. Any other use change shall require a zoning amendment of this site.  
The City of Amarillo or its franchised utility shall not be required to replace any obstructions, paving or plantings that must be removed during the course of maintenance, construction, or reconstruction within any public utility or drainage easement.  
All exterior mechanical equipment shall be located and/or screened in such a manner as to eliminate or minimize noise and visual impact to adjacent properties.  
All surface storm water collected on this site shall drain directly to adjacent public right-of-way or by other means if approved by the City Engineer.  
The developer shall comply with the ADA-TAS requirements  
I acknowledge and agree to all standards of development as listed on this site plan.

Name of developer \_\_\_\_\_  
Date \_\_\_\_\_



### Project Location

#### Landscape Ordinance Compliance Schedule

Landscaping Requirements:	
A. Total Parking Lot Area:	17,710
B. Total Building Footprint:	0000
C. Total Required Landscaped Area:	1,710
D. Total Area of Living Landscape Required:	655
E. Total Area of Non-Living Landscape Provided:	2,059
F. Total Area of Non-Living Landscape Provided:	0000
Street Tree Requirements:	
G. Total Length of Street Frontage:	150
H. Total Number of Trees Required Per Street Frontage:	4
I. Total Number of Trees Provided Per Street Frontage:	4
Parking Lot Tree Requirements:	
J. Total Number of Parking Spaces:	62
K. Total Number of Trees Required Per Parking Spaces:	3
L. Total Number of Trees Provided Per Parking Spaces:	3

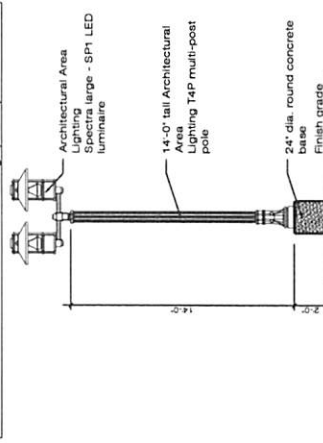

2 PARKING LOT LIGHT POLE

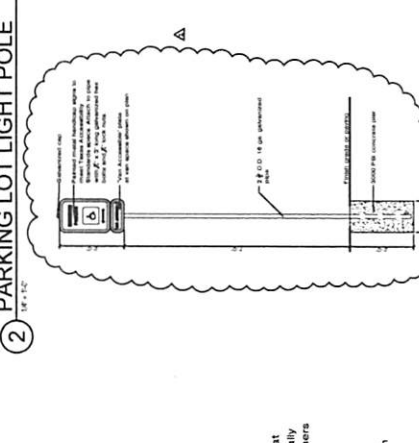

5 TYPICAL HANDICAPPED SIGN



1 DETAIL - DRIVE APPROACH

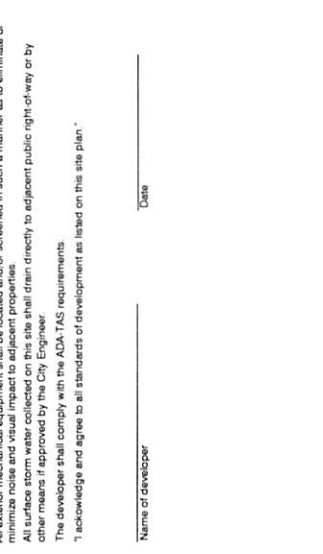

3 FRONT SCREEN WALL ELEVATION

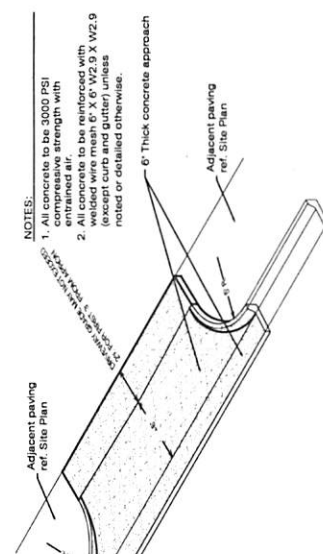

4 SCREEN WALL ELEVATION

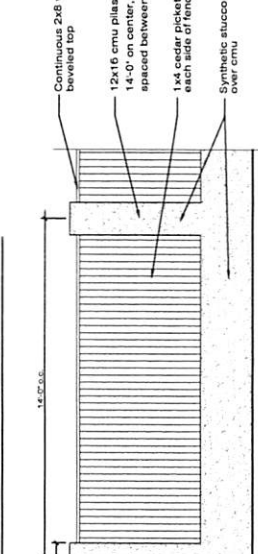

1 DETAIL - DRIVE APPROACH

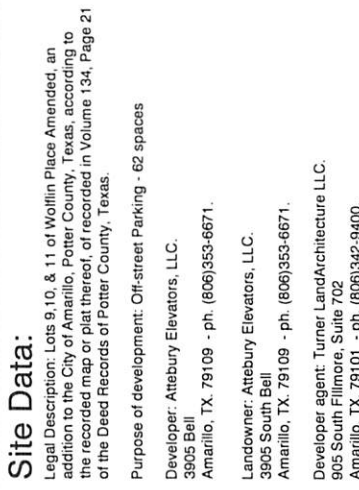

3 FRONT SCREEN WALL ELEVATION

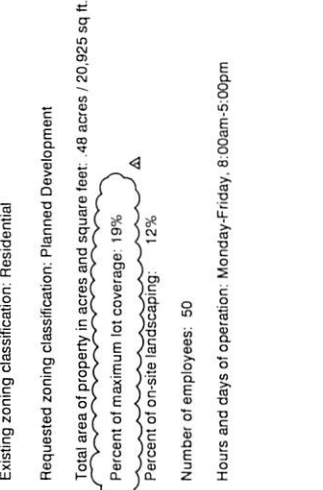

1 DETAIL - DRIVE APPROACH



4 SCREEN WALL ELEVATION

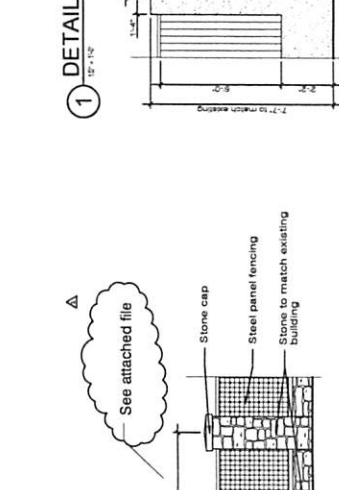

5 TYPICAL HANDICAPPED SIGN

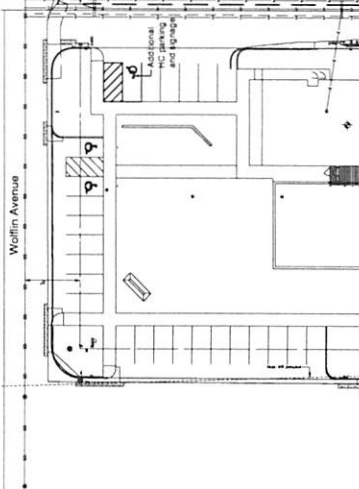

1 DETAIL - DRIVE APPROACH

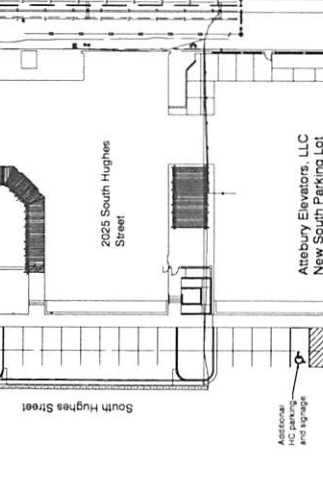

3 FRONT SCREEN WALL ELEVATION

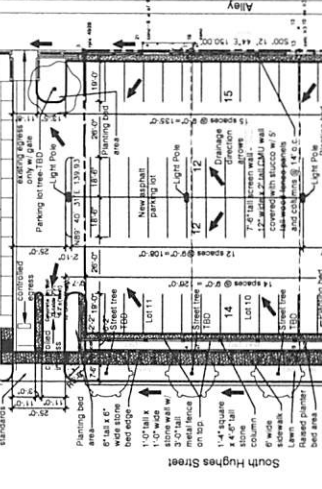

1 DETAIL - DRIVE APPROACH

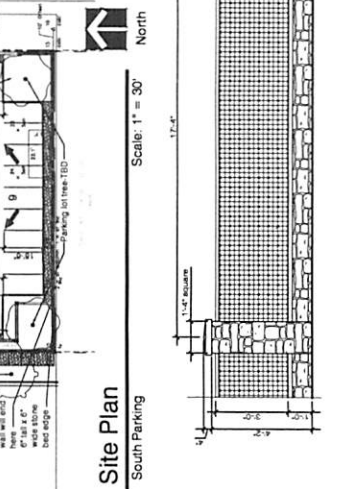

4 SCREEN WALL ELEVATION

**Turner LandArchitecture LLC**  
Landscape Architecture & Planning 1306 Street  
3905 Bell, Amarillo, TX 79109  
Phone: 806.342.9400  
Fax: 806.342.9401  
www.turnerlandscape.com

**PLANNED DEVELOPMENT REZONING PLAN FOR ATEBURY ELEVATORS LLC**

885 SOUTH HUGHES AMARILLO, TEXAS 79109

REVISIONS:  
 ▲ ISSUE DATE DESCRIPTION  
 ▲ 09-29-17

CONSULTANT:

DATE: 09-15-2017  
 PROJECT: PAS-08-11A  
 SCALE: 1"=40'  
 DRAWN BY: JS

SHEET TITLE:  
 PLANNED DEVELOPMENT REZONING SITE PLAN  
 SHEET NUMBER:

PD-1.00



**CASE Z-17-13**  
**REZONING FROM PLANNED DEVELOPMENT 278 (PD-278),**  
**PLANNED DEVELOPMENT 278A (PD-278A),**  
**& RESIDENTIAL 1 (R-1) TO PLANNED DEVELOPMENT (PD)**

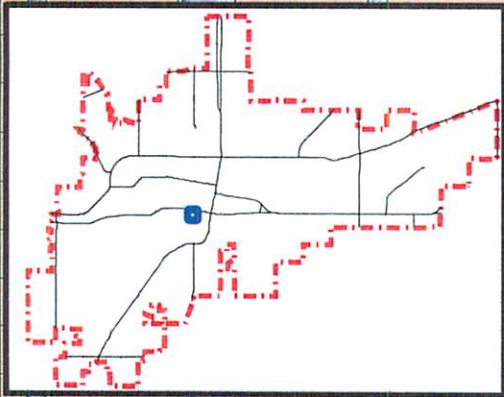
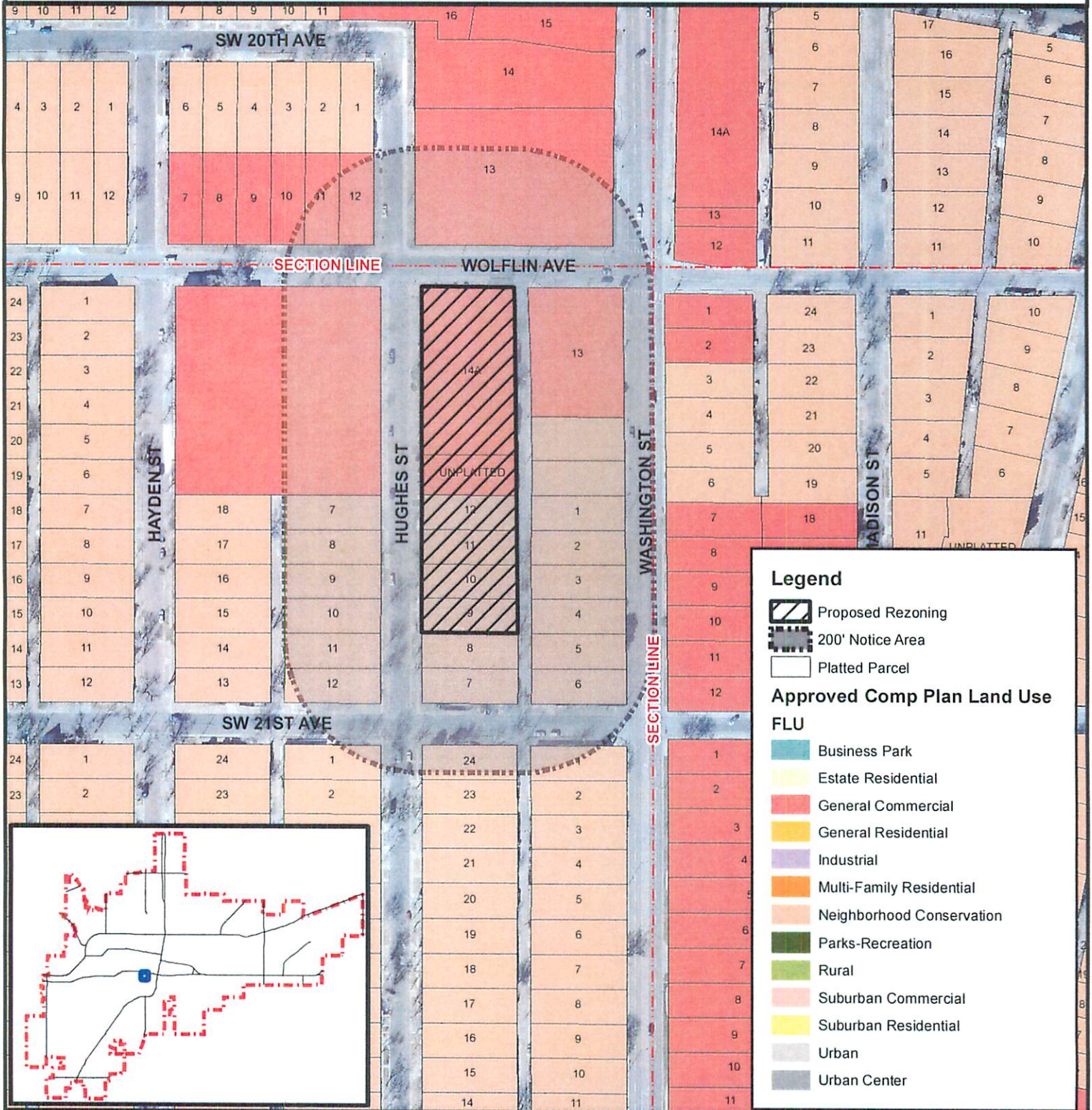

**CITY OF AMARILLO**  
**PLANNING DEPARTMENT**

**Scale: 1 inch = 200 feet**  
**Date: 5/23/2017**



Rezoning of Lots 9,10,11,12, and 14A, Wolflin Place AMD, in Section 186, Block 2, AB&M Survey, Potter County, Texas plus one-half of all bounding streets, alleys, and public ways to change from Planned Development District 278, 278A, and Residential District 1 (R-1) to amended Planned Development District.

Applicant: Attebury Elevators

Vicinity: Hughes St. & Wolflin Ave

DISCLAIMER: The City of Amarillo is providing this information as a public service. The information shown is for information purposes only and except where noted, all of the data or features shown or depicted on this map is not to be construed or interpreted as accurate and/or reliable; the City of Amarillo assumes no liability or responsibility for any discrepancies or errors for the use of the information provided.

**CASE Z-17-13  
 REZONING FROM PLANNED DEVELOPMENT 278 (PD-278),  
 PLANNED DEVELOPMENT 278A (PD-278A),  
 & RESIDENTIAL 1 (R-1) TO PLANNED DEVELOPMENT (PD)**

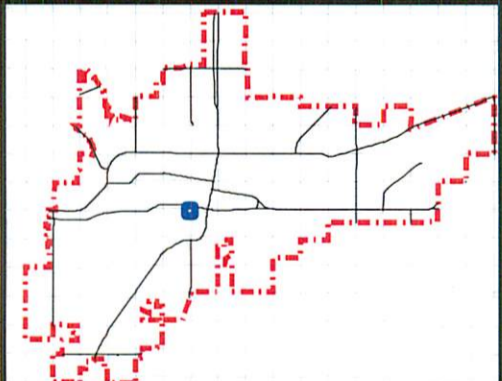
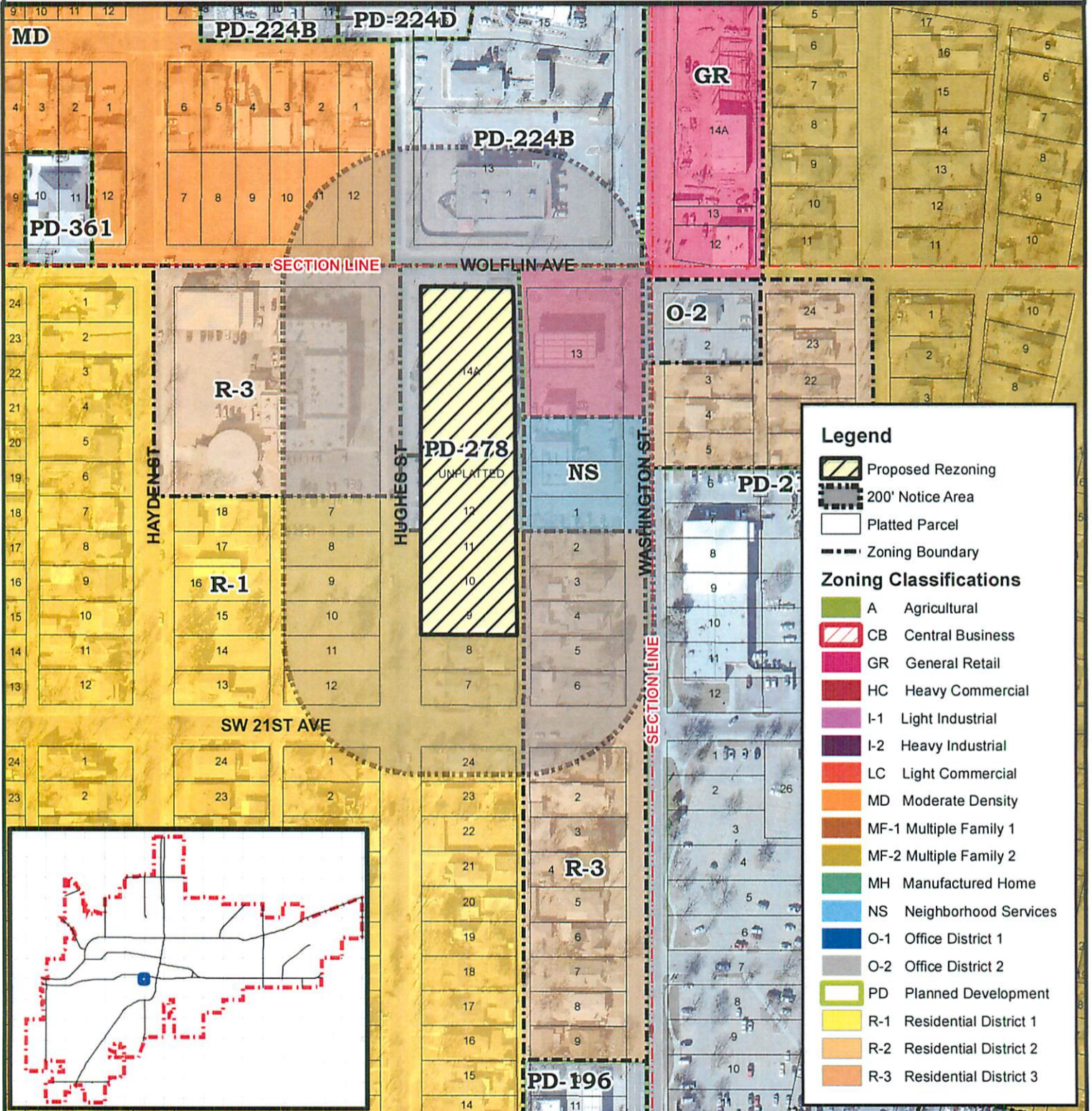

**CITY OF AMARILLO  
 PLANNING DEPARTMENT**

**Scale: 1 inch = 200 feet**  
**Date: 6/2/2017**



Rezoning of Lots 9,10,11,12, and 14A, Wolflin Place AMD, in Section 186, Block 2, AB&M Survey, Potter County, Texas plus one-half of all bounding streets, alleys, and public ways to change from Planned Development District 278, 278A, and Residential District 1 (R-1) to amended Planned Development District.

Applicant: Attebury Elevators

Vicinity: Hughes St. & Wolflin Ave

DISCLAIMER: The City of Amarillo is providing this information as a public service. The information shown is for information purposes only and except where noted, all of the data or features shown or depicted on this map is not to be construed or interpreted as accurate and/or reliable; the City of Amarillo assumes no liability or responsibility for any discrepancies or errors for the use of the information provided.

Looking north on Hughes St. Proposed rezoning to the right.



Looking north on Hughes St. Wolflin Elementary on the left.



At the intersection of Hughes St. & SW 21<sup>st</sup> Ave looking south.







# Amarillo City Council Agenda Transmittal Memo



<b>Meeting Date</b>	06/27/17	<b>Council Priority</b>	Downtown Redevelopment
---------------------	----------	-------------------------	------------------------

<b>Department</b>	City Manager's Office
-------------------	-----------------------

**Agenda Caption**  
Ordinance – An Ordinance amending established parking fees for the parking garage.

**Agenda Item Summary**  
This item is reading and approval of an ordinance amending the rates for use of the parking garage. Specifically, this amendment adds to the established rates – rates for Special Event parking (\$7.00-\$10.00), monthly lease rates for M-F business hour parking (\$1,300 annually) and annual (24/7 access) rates (\$1,500 annually).

**Requested Action**  
Conduct the readings and approval of the ordinance.

**Funding Summary**  
Revenue generated from the parking operations address operations expenses and service the debt used in the construction of the parking garage.

**Community Engagement Summary**  
N/A

**City Manager Recommendation**  
Staff recommends approval of the Ordinance.

ORDINANCE NO. 7671

AN ORDINANCE OF THE CITY COUNCIL OF THE CITY OF AMARILLO: REGULATING PARKING WITHIN THE DOWNTOWN PARKING GARAGE; AMENDING PARKING FEES; PROVIDING SEVERABILITY CLAUSE; PROVIDING A REPEALER CLAUSE; PROVIDING FOR CRIMINAL PENALTY; PROVIDING FOR PUBLICATION AND EFFECTIVE DATE.

---

WHEREAS, the Downtown Parking Garage, to be operated by the City under an Agreement with the Amarillo Local Government Corporation, shall be available for public parking and for parking pursuant to Agreement with either the City of Amarillo or the Amarillo Local Government Corporation; and

WHEREAS, the City Council finds that it is in the best interests of both public safety and convenience to take each action below related to fees for parking within the Downtown Parking Garage;

NOW, THEREFORE, BE IT ORDAINED BY THE CITY COUNCIL OF THE CITY OF AMARILLO, TEXAS:

SECTION 1. That the following fees for public parking in the Downtown Parking Garage be are hereby AMENDED as follows:

DOWNTOWN PARKING GARAGE PARKING DAILY RATES

<u>Period</u>	<u>Rate</u>	<u>Rate incl. Tax</u>
0 - 2 Hour	\$1.85	\$2.00
Each Additional 2 Hour	\$1.85	\$2.00
Maximum Per Day	\$6.47	\$7.00

PARKING PROVIDED UNDER AGREEMENT WITH LGC OR CITY

- (1) Monthly Lease: \$25.00 per work-week (M-F, between hours of 7:00 am and 6:00 pm), \$1,300.00 annually with 12 month lease;
- (2) Full Access Lease (24-hours, 7-day a week access): \$30.00 per week, \$1,500.00 annually with 12 month lease; or
- (3) As provided in the Agreement.

\*\* The above rates include Tax.

EVENT PARKING RATES

- (1) \$7.00 TO \$10.00 per day, as determined by CITY garage operator for each event.

\*\* The above rates include Tax.

Notes: (1) Sales tax currently at 8.25%,  
(2) Customers with valid handicapped license plates do not pay for parking,  
(3) Rates are set so the customer can pay with minimal use of change, avoiding pennies, after tax is applied.

**SECTION 2.** That fees for parking provided under an Agreement between either the City of Amarillo or the Amarillo Local Government Corporation and a person, firm or corporation, shall be charged and paid at such rates as are provided in such Agreement.

**SECTION 3.** That should any part of this resolution conflict with any other resolution, then such other resolution is repealed to the extent of the conflict with this resolution.

**SECTION 4.** That should any word, phrase, or part of this resolution be found to be invalid or unconstitutional, such finding shall not affect any other word, phrase, or part hereof and such shall be and continue in effect.

**SECTION 5.** Penalty. Upon conviction for a violation of this ordinance, the offender shall be subject to fine or other penal or civil sanctions as prescribed in Section 1-1-5 or as otherwise provided by law.

**SECTION 6.** Publication and Effective Date. This ordinance shall be published and become effective according to law.

**INTRODUCED AND PASSED** by the City Council of the City of Amarillo, Texas, on First Reading this the 20<sup>th</sup> day of June, 2017; and **PASSED** on Second and Final Reading the 27<sup>th</sup> day of June, 2017.

\_\_\_\_\_  
Ginger Nelson, Mayor

**ATTEST:**

\_\_\_\_\_  
Frances Hibbs, City Secretary

**APPROVED AS TO FORM:**

\_\_\_\_\_  
William M. McKamie, City Attorney



# Amarillo City Council Agenda Transmittal Memo



<b>Meeting Date</b>	June 27, 2017	<b>Council Priority</b>	Infrastructure and Best Practices
---------------------	---------------	-------------------------	-----------------------------------

<b>Department</b>	City Manager's Office	<b>Contact Person</b>	
-------------------	-----------------------	-----------------------	--

### Agenda Caption

Resolution – A Resolution denying the surcharge related to Docket No. 45524 submitted by Southwestern Public Service Company, authorizing participating in a coalition of similarly situated cities, authorizing participation in related rate proceedings, requiring the reimbursement of municipal rate case expenses, and authorizing the retention of special counsel.

### Agenda Item Summary

This item is approval of a Resolution denying a surcharge requested by SPS related to a rate case settlement in 2016. The City of Amarillo along with a number of other West Texas cities approved a settlement with SPS on a rate request and the Public Utility Commission of Texas approved an increase of \$35 million in annual revenue for SPS. The PUCT approval occurred on December 10, 2016 with an effective date of July 20, 2016. SPS has a statutory right to collect the difference in revenue between the rates it charged during the period from July 20, 2016 to December 9, 2016. There exists concern regarding the proposed amount of the proposed surcharge (413.8 million). The most expedient and cost-effective way to have this concern addressed is to deny the request, which upon appeal by SPS will be resolved by the PUCT.

### Requested Action

Approve the Resolution

### Funding Summary

It is anticipated the surcharge, once approved by the PUCT will be implemented over a 5-month period. The impact of the surcharge will be upon all rate payers including the City. The exact impact will not be known until the PUCT makes a final determination.

### Community Engagement Summary

NA

### Staff Recommendation

Staff recommends approval of the Resolution.

RESOLUTION NO. \_\_\_\_\_

**RESOLUTION BY THE CITY OF AMARILLO, TEXAS (“CITY”) DENYING THE SURCHARGE RELATED TO DOCKET NO. 45524 SUBMITTED BY SOUTHWESTERN PUBLIC SERVICE COMPANY ON ABOUT APRIL 6, 2017; AUTHORIZING PARTICIPATION IN A COALITION OF SIMILARLY SITUATED CITIES; AUTHORIZING PARTICIPATION IN RELATED RATE PROCEEDINGS; REQUIRING THE REIMBURSEMENT OF MUNICIPAL RATE CASE EXPENSES; AUTHORIZING THE RETENTION OF SPECIAL COUNSEL; FINDING THAT THE MEETING COMPLIES WITH THE OPEN MEETINGS ACT; MAKING OTHER FINDINGS AND PROVISIONS RELATED TO THE SUBJECT; AND DECLARING AN EFFECTIVE DATE**

WHEREAS, on about April 6, 2017, Southwestern Public Service Company, LLC (“SPS”) filed an application for authority to implement a surcharge related to Docket No. 45524; and

WHEREAS, the City is a regulatory authority under the Public Utility Regulatory Act (“PURA”) and under Chapter 33, §33.001 et seq. of PURA has exclusive original jurisdiction over SPS’s rates, operations, and services within the municipality; and

WHEREAS, the amount of SPS’s proposed surcharge is \$13.7 million; and

WHEREAS, SPS proposes to implement the surcharge over a five-month period from July 1, 2017 through November 30, 2017; and

WHEREAS, the City will require the assistance of specialized legal counsel and rate experts to review the merits of SPS’s application to implement the surcharge, and in particular to confirm the accuracy of SPS’s calculations of its proposed surcharge; and

WHEREAS, in order to maximize the efficient use of resources and expertise in reviewing SPS’s request it is prudent to coordinate the City’s efforts with a coalition of similarly situated municipalities; and

WHEREAS, the City, in matters regarding SPS’s rates, services, and operations has in the past joined with other local regulatory authorities in the Alliance of Xcel Municipalities (“AXM”) of cities and hereby continues its participation in AXM; and

WHEREAS, SPS simultaneously filed its application to implement a surcharge with the Public Utility Commission of Texas, therefore the decision of the Public Utility Commission of Texas could have an impact on the rates charged within the City and in order for the City’s participation to be meaningful it is important that the City promptly intervene in such proceeding at the Public Utility Commission of Texas; and

WHEREAS, SPS failed to show that its proposed surcharge is reasonable and therefore the City has concluded that SPS’s proposed rate increase is unreasonable.

**NOW THEREFORE, BE IT RESOLVED BY THE CITY COUNCIL OF THE CITY OF AMARILLO, TEXAS THAT:**

**Section 1.** The findings set out in the preamble are in all things approved and incorporated herein as if fully set forth.

**Section 2.** The City **DENIES** SPS's application filed on about April 6, 2017 to implement a net surcharge.

**Section 3.** The City authorizes intervention in proceedings related to SPS's application before the Public Utility Commission of Texas and related proceedings in courts of law as part of the coalition of cities known as the Alliance of Xcel Municipalities ("AXM").

**Section 4.** The City hereby orders SPS to reimburse the City's rate case expenses, as part of the Alliance of Xcel Municipalities, and that it do so on a monthly basis and within 30 days after submission of the City's invoices related to its review of the proposed surcharge or to related proceedings involving SPS before the City, the Public Utility Commission of Texas, or any court of law.

**Section 5.** Subject to the right to terminate employment at any time, the City retains and authorizes the law firm of Herrera & Boyle, PLLC to act as Special Counsel with regard to rate proceedings involving SPS before the City, the Public Utility Commission of Texas, or any court of law and to retain such experts as may be reasonably necessary for review of SPS's surcharge application subject to approval by the City.

**Section 6.** The City shall review the invoices of the lawyers and rate experts for reasonableness before submitting the invoices to SPS for reimbursement.

**Section 7.** A copy of this resolution shall be sent to SPS, care of Jeremiah W. Cunningham, Rate Case Manager, Southwestern Public Service Company, P.O. Box 1261, Amarillo, Texas 79105; and to Mr. Alfred R. Herrera, Herrera & Boyle, PLLC, 816 Congress Ave., Suite 1250, Austin, Texas 78701.

**Section 8.** This resolution shall become effective from and after its passage.

**PASSED AND APPROVED** this \_\_\_\_\_ day of June, 2017.

\_\_\_\_\_  
Ginger Nelson, Mayor

**ATTEST:**

\_\_\_\_\_  
Frances Hibbs, City Secretary

**APPROVED AS TO FORM:**

\_\_\_\_\_  
Mick McKamie, City Attorney

**AGENDA INFORMATION SHEET**

**ITEM NO. \_\_\_\_\_**

**BACKGROUND**

On April 6, 2017, Southwestern Public Service Company ("SPS") filed an application with the City and the Public Utility Commission of Texas ("Commission" or "PUC") for approval to implement a surcharge arising from its most recent base rate case, Docket No. 45524. The purpose of the surcharge is to allow SPS to recover revenue that it has a statutory right to recover for the period from July 20, 2016 through December 9, 2016.

In SPS's most recently completed general rate case, the City as part of the Alliance of Xcel Municipalities ("AXM") and the PUC in Docket No. 45524, approved the parties' settlement, which granted SPS an increase in revenue of about \$35 million. The PUC's approval occurred on December 10, 2016. Under state law the rates approved on December 10, 2016 "relate back" to the 155th day after SPS filed its application to increase rates. SPS filed its application on February 16, 2016; the 155th day after February 16th is July 20, 2016.

SPS's proposed surcharge would allow SPS to recover revenues that it would have recovered if the rates approved on December 10, 2016, had been in effect from July 20, 2016 through December 9, 2016. The amount of the proposed surcharge is about \$13.7 million in total revenue and SPS proposes to recover the surcharge over a five-month period from July 1, 2017 through November 30, 2017. The surcharge will be applied as a percentage of a customer's base-rate bill. Note that for a few customer classes, instead of a surcharge, will receive a credit on their bills. The table below shows the amounts SPS proposes to recover from each class of customers and the corresponding percentage surcharge or credit.

<b><u>Class or Subclass</u></b>	<b><u>Proposed True-up Rate</u></b>	<b><u>Surcharge/(Credit)</u></b>
Residential Service	4.34%	\$ 2,820,708
Residential Service with Space Heating	4.75%	\$ 899,012
Small General Service	13.05%	\$ 1,194,818
Secondary General Service	11.27%	\$ 5,677,101
Small Municipal and School Service	(0.57%)	\$ (3,268)
Large Municipal Primary Service	8.59%	\$ 29,997
Large Municipal Secondary Service	0.40%	\$ 9,486
Large School Primary Service	11.06%	\$ 7,810
Large School Secondary Service	11.83%	\$ 630,645
Primary General Service	7.19%	\$ 2,035,253

SAS-4	Individual Customer Calculations	\$ 115,100
SAS-8	Individual Customer Calculations	\$ 29,697
Primary - Low Load Factor	Individual Customer Calculations	\$ 3,128
Street Lighting Service	(6.74%)	\$ (109,641)
SAS-805	Individual Customer Calculations	\$ (34)
Flood Lighting	(12.41%)	\$ (54,483)
Guard Lighting	(11.30%)	\$ (125,067)
SAS-810	Individual Customer Calculations	\$ (227)
Large General Service - Transmission 69-115 kv	Individual Customer Calculations	\$ 58,090
Large General Service - Transmission 115+ kv	Individual Customer Calculations	\$ 552,095
<b>Total</b>		<b>\$ 13,770,220</b>

## **REPRESENTATION**

The law firm of Herrera & Boyle, PLLC (through Mr. Alfred R. Herrera) has previously represented the Alliance of Xcel Municipalities in rate matters involving SPS. Similarly, the firm of Herrera & Boyle, PLLC has represented other Texas cities dealing with rate case matters, therefore providing a depth of experience in dealings with SPS and the Commission.

## **RATE CASE EXPENSES**

Cities, by statute, are entitled to recover their reasonable rate case expenses from the utility. Legal counsel and consultants approved by the City will submit monthly invoices to the City that will be forwarded to AXM for reimbursement.

## **INTERVENTION AT THE PUBLIC UTILITY COMMISSION OF TEXAS AND COURT PROCEEDINGS, IF ANY**

SPS filed its request for approval of a surcharge related to Docket No. 45524 with the City on the same date it filed its application with the PUC. It is important to participate in the PUC's proceeding because its final decision may impact rates within the City. Thus, the accompanying Resolution authorizes intervention in proceedings at the PUC, including any appeal of the City's decisions on rates. An intervention deadline has not yet been established. However, the



Commission's procedural rules provide for a "default" intervention deadline of 45 days after filing, which in this case is May 21, 2017. However, May 21, 2017 is a Sunday and the Commission is not open for business on that date. This means that a likely intervention deadline will be May 22, 2017.

### **RECOMMENDATION**

It is recommended that the City deny SPS's application to implement the proposed surcharge related to Docket No. 45524. While an intervention deadline has not yet been established and the proposed effective date of the tariff authorizing the surcharge is not effective until July 1, 2017, it is recommended that the City take action as soon as possible to allow for full participation in proceedings before the PUC.

It is also recommended that the City retain the law firm of Herrera & Boyle, PLLC to represent the City's interest in matters related to SPS's surcharge application and to advise the City with regard to SPS's application, and that the City intervene in the proceeding before the PUC, and represent the City in appeals, if any, regarding SPS's application.



# Amarillo City Council Agenda Transmittal Memo



<b>Meeting Date</b>	June 27, 2017	<b>Council Priority</b>	Regular agenda Item
---------------------	---------------	-------------------------	---------------------

<b>Department</b>	Planning Department
-------------------	---------------------

### Agenda Caption

Vicinity: A one block segment of Pinnacle Drive between Coulter Street and Paragon Drive

Consideration of renaming a segment of Pinnacle Drive to Westover Parkway.

### Agenda Item Summary

Canyon ISD is moving forward with construction of a new intermediate school within the future Pinnacle neighborhood. The district has consistently named campuses after the neighborhood within which they are located as both a matter of convenience and of public safety/communications. The existing Westover Park Jr. High is on a street currently named Pinnacle Drive. Obviously, residents have grown accustomed to the schools being named in conjunction with the surrounding neighborhood, and this could create substantial confusion for residents and parents. As such, CISD is requesting the City of Amarillo to consider renaming this street segment, which extends for one block east of Coulter Street, a major arterial road, and break in the existing Pinnacle Drive.

### Requested Action

The applicant is requesting that the City Council approve this proposed street renaming.

### Funding Summary

N/A

### Community Engagement Summary

The item was distributed to all applicable internal and external entities. Notices have been sent out to property owners within 200 feet regarding this proposed street renaming.

Planning staff has met with CISD staff, and in accordance with the adopted City of Amarillo street renaming policy adopted in November of 2016, the item was considered by City Council on May 30<sup>th</sup>.

A general informational meeting took place on Wednesday June 21<sup>st</sup>. Two of the fifteen property owners notified attended the meeting. While not opposed to the renaming of this segment, they did express a desire to see the entirety of Pinnacle Dr. renamed, in order to avoid confusion.

### City Manager Recommendation

# Amarillo City Council

## Agenda Transmittal Memo



---

Staff recommends approval, with two considerations:

1. Have Council consider an alternate street name, as a Westover Place already exists just north of this property, and within the same section; and,
2. If Council so desires, a separate renaming effort for the remainder of Pinnacle Dr. could be pursued, to create a consistent street name throughout.

---

### Attachments

1. Letter from Canyon ISD
  2. Map of area
-

# Amarillo City Council Agenda Transmittal Memo



## Canyon Independent School District

**Heather Wilson**  
Chief Financial Officer

**Darryl Flusche**  
Superintendent

May 30, 2017

A.J. Fawver, AICP, CNU-P  
Planning Director  
P.O. Box 1971  
Amarillo, TX 79105-1971

Dear Sirs:

Canyon Independent School District (CISD) is currently in the process of building a new intermediate school in South Amarillo, within the future Pinnacle Neighborhood. The district has a practice of naming our campuses after the neighborhood within which they are located. This allows parents, law enforcement and the community to easily locate each campus.

In following the same practice with naming our schools located within the Amarillo city limits, a concern has arisen. Our current Westover Park Junior High School is on Pinnacle Drive. We feel if parents were to search on the internet for CISD Pinnacle Intermediate School, confusion could arise as to whether they were looking for a campus address or a campus name. With this being said, CISD respectfully requests the City of Amarillo to consider renaming the street between Coulter and Paragon to Westover Parkway.

Thank you in advance for your consideration of our request.

Sincerely,

A handwritten signature in blue ink, appearing to read 'Heather Wilson'.

Heather Wilson  
Chief Financial Officer

Attachment: Aerial View of Pinnacle Drive

LHW/kl

# Amarillo City Council Agenda Transmittal Memo

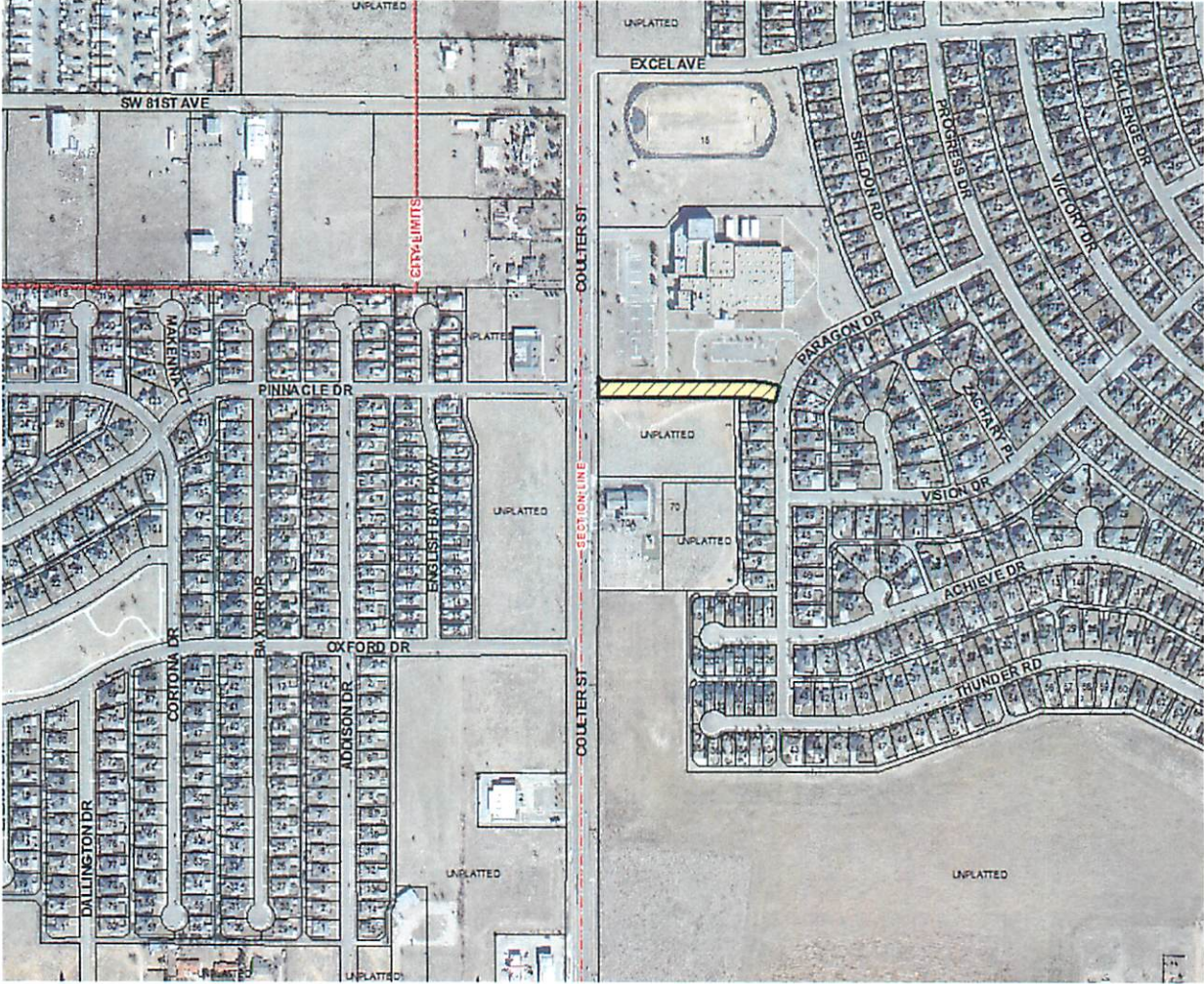

RESOLUTION NO. \_\_\_\_\_

A RESOLUTION OF THE CITY OF AMARILLO, TEXAS:  
RENAMING PUBLICLY DEDICATED STREETS,  
FORMERLY KNOWN AS PINNACLE DRIVE TO  
WESTOVER PARKWAY, AS IS MORE FULLY  
DESCRIBED HEREIN; PROVIDING A SAVINGS CLAUSE;  
PROVIDING A REPEALER CLAUSE; AND PROVIDING AN  
EFFECTIVE DATE.

---

BE IT ORDAINED BY THE CITY COUNCIL OF THE CITY OF AMARILLO  
TEXAS:

SECTION 1. That a segment of the publicly dedicated street right-of-way heretofore known as Pinnacle Drive located in Section 31, Block 9, B.S. & F Survey, Randall County, Texas is hereby renamed to Westover Parkway.

SECTION 2. All ordinances and resolutions or parts thereof that conflict with this ordinance are hereby repealed, to the extent of such conflict.

SECTION 3. In the event this resolution or any part hereof is found to be invalid, such invalidity shall not affect the remaining portions of the resolution, and such remaining portions shall continue to be in full force and effect.

SECTION 4. That this resolution shall become effective immediately upon passage and approval.

INTRODUCED AND PASSED by the City Council of the City of Amarillo, Texas, this \_\_\_\_ day of June 2017.

\_\_\_\_\_  
Ginger Nelson, Mayor

ATTEST:

\_\_\_\_\_  
Frances Hibbs, City Secretary

# CASE M-17-02 PINNACLE DR RENAMING

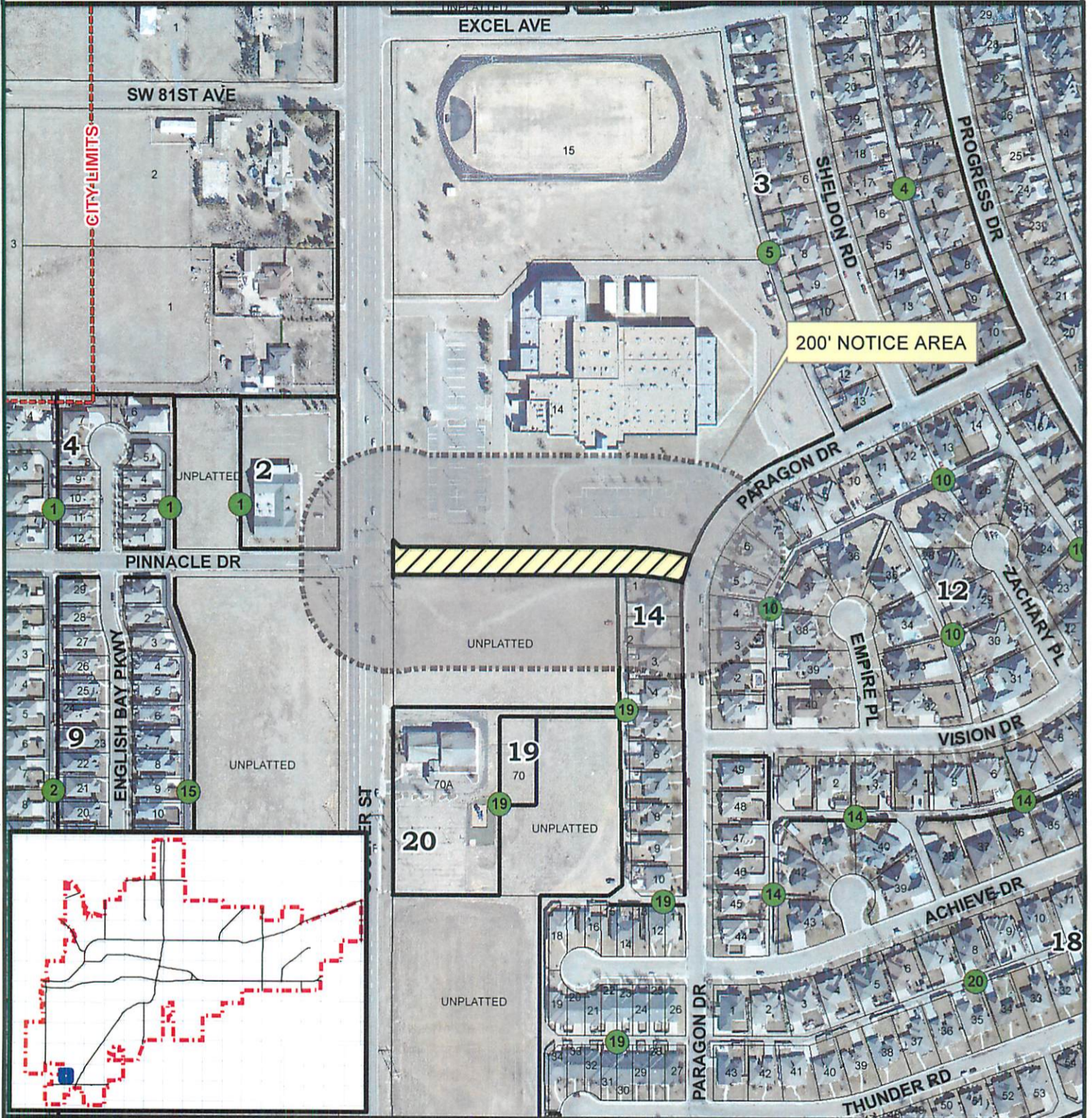

**CITY OF AMARILLO  
PLANNING DEPARTMENT**

Street name change request to rename a portion of Pinnacle Drive to Westover Parkway, in Section 31, Block 9, BS&F Survey, Randall County, Texas.

Applicant: Heather Wilson

Vicinity: Coulter St & Paragon Dr

**Scale: 1 inch = 300 feet**  
**Date: 6/13/2017**



DISCLAIMER: The City of Amarillo is providing this information as a public service. The information shown is for information purposes only and except where noted, all of the data or features shown or depicted on this map is not to be construed or interpreted as accurate and/or reliable; the City of Amarillo assumes no liability or responsibility for any discrepancies or errors for the use of the information provided.



# Amarillo City Council Agenda Transmittal Memo



<b>Meeting Date</b>	June 27, 2017	<b>Council Priority</b>	Infrastructure Initiative
---------------------	---------------	-------------------------	---------------------------

<b>Department</b>	Capital Projects & Development Engineering
-------------------	--

### Agenda Caption

**Award –Bid # 5714 Job# 560062: Arden Road Storm Sewer and Playa #7 Excavation – Phase I**

**CONTRACTOR - \$ 2,418,171.41**

This item is to approve the contract for the Arden Road Storm Sewer and Playa #7 Excavation – Phase I. This proposed project will consist of the installation of storm sewer in future Arden Road to serve the adjacent subdivisions. The storm sewer will cross Loop 335 (Soncy Road) and discharge into Playa #7 (Greenways Playa) which will be excavated as part of this project to allow the storm sewer to discharge. The installation will include repair of pavement in Loop 335 where the storm sewer line is crossing the road.

### Agenda Item Summary

Award of Contract for the Arden Road Storm Sewer and Playa #7 Excavation – Phase I

### Requested Action

Consider approval and award to Williams Ditching, LLC - \$ 2,418,171.41

### Funding Summary

Funding for this project is available in the approved Capital Improvement Program Budget Number 560062.17400.1040.

### Community Engagement Summary

This project will have **modest impact** to the neighborhood. City staff will continually update the public with press releases and public announcements through social media before and during the project. The Project Manager will send notifications to the adjacent property owners prior to construction for affected citizens.



Amarillo City Council  
Agenda Transmittal Memo



---

**Staff Recommendation**

City Staff is recommending approval and award of the contract.

---

Bid No. 5714 Arden Road Storm Sewer and Playa #7 Excavation- Phase 1  
 Opened 4:00 p.m., April 27, 2017

To be awarded by line item	Williams Ditching LLC	Holmes Construction Company	Spiess Construction Co Inc	L A Fuller & Sons Construction Ltd	D E Rice Construction Company Inc
Line 1 Construction Item - Layout and Survey to include slope staking, construction staking and other associated staking (COA 10.06) complete, per specifications					
1 ls					
Unit Price	\$120,293.000	\$17,200.00	\$30,000.000	\$41,630.00	\$40,000.000
Extended Price	120,293.00	17,200.00	30,000.00	41,630.00	40,000.00
Line 2 Excavation, regrading and channel grading to the slopes shown on the plans, (COA 4.02) complete, per specifications					
253,000 cy					
Unit Price	\$4.070	\$6.55	\$10.000	\$8.05	\$8.000
Extended Price	1,029,710.00	1,657,150.00	2,530,000.00	2,036,650.00	2,024,000.00
Line 3 Trenching, supplying, laying, joining, and backfilling for sixty inch (60") HDPE storm sewer, (COA 5.052) installed complete, per specifications					
80 lf					
Unit Price	\$164.530	\$323.00	\$100.000	\$199.00	\$325.000
Extended Price	13,162.40	25,840.00	8,000.00	15,920.00	26,000.00

To be awarded by line item	Williams Ditching LLC	Holmes Construction Company	Spieess Construction Co Inc	L A Fuller & Sons Construction Ltd	D E Rice Construction Company Inc
Line 4 Furnish, install and maintain Traffic control Plan, (COA 9.04) complete, per specifications					
1 ls	\$9,623.000	\$36,450.00	\$75,000.000	\$49,000.00	\$10,000.000
Unit Price					
Extended Price	9,623.00	36,450.00	75,000.00	49,000.00	10,000.00
Line 5 Mobilization / Demobilization including Insurance, Payment Bond, Performance Bond, Maintenance Bond and related Ancillary Costs. (Shall not exceed five percent (5%) of the total construction cost(COA 10.01), per specifications					
1 ls	\$104,949.860	\$131,100.00	\$175,000.000	\$128,040.00	\$65,300.000
Unit Price					
Extended Price	104,949.86	131,100.00	175,000.00	128,040.00	65,300.00
Line 6 Remove Stab Base & Asph Pav (8" - 20"), complete, per specifications					
145 sy	\$7.380	\$52.00	\$20.000	\$24.00	\$35.000
Unit Price					
Extended Price	1,070.10	7,540.00	2,900.00	3,480.00	5,075.00

To be awarded by line item	Williams Ditching LLC	Holmes Construction Company	Spiess Construction Co Inc	L A Fuller & Sons Construction	D E Rice Construction Company
Line 7 Furnish, haul, place and compact new fill, select material (Pl<15). Material is to be placed in lifts not to exceed six inches (6") and compacted to 95% Proctor, (TxDOT Item No 132), complete , per specifications					
28 cy					
Unit Price	\$94.290	\$201.00	\$50.000	\$115.00	\$150.000
Extended Price	2,640.12	5,628.00	1,400.00	3,220.00	4,200.00
Line 8 Drill Seed (Perm)(Urban)(Clay), complete, per specifications					
115,000 sy					
Unit Price	\$0.120	\$0.60	\$0.500	\$0.65	\$0.150
Extended Price	13,800.00	69,000.00	57,500.00	74,750.00	17,250.00
Line 9 Sediment control, Soil Retention Blanket, (Flexible Channel Liner) (Class 2 Type F), (TxDOT Item No 169) installed complete per specifications					
31,000 sy					
Unit Price	\$0.770	\$0.76	\$0.500	\$1.20	\$2.000
Extended Price	23,870.00	23,560.00	15,500.00	37,200.00	62,000.00
Line 10 FL BS (CMP in PLC)(TY A or B)(GR 4)(12") complete, per specifications					
145 sy					
Unit Price	\$31.760	\$83.45	\$15.000	\$38.00	\$66.000
Extended Price	4,605.20	12,100.25	2,175.00	5,510.00	9,570.00

To be awarded by line item	Williams Ditching LLC	Holmes Construction Company	Spieess Construction Co Inc	Ltd	Inc
Line 11 D-GR HMA (SQ) TY-B PG64-22, (TxDOT Item No 3267) complete per specifications					
34 Ton					
Unit Price	\$104.060	\$302.00	\$100.000	\$443.00	\$220.000
Extended Price	3,538.04	10,268.00	3,400.00	15,062.00	7,480.00
Line 12 D-GR HMA (SQ) Ty-D PG64-22, )TxDOT Item No 3267) complete, per specifications					
17 Ton					
Unit Price	\$270.060	\$300.00	\$100.000	\$670.00	\$440.000
Extended Price	4,591.02	5,100.00	1,700.00	11,390.00	7,480.00
Line 13 Trench Excavation Protection, compele, per specifications					
1,531 LF					
Unit Price	\$12.920	\$9.75	\$1.000	\$27.00	\$10.000
Extended Price	19,780.52	14,927.25	1,531.00	41,337.00	15,310.00
Line 14 RIPRAP (Conc)(4IN) complete, per specifications					
40 CY					
Unit Price	\$226.500	\$495.00	\$500.000	\$612.00	\$105.000
Extended Price	9,060.00	19,800.00	20,000.00	24,480.00	4,200.00
Line 15 RIPRAP (Stone Common (Dry))(18 IN) complete, per specifications					
16 CY					
Unit Price	\$206.940	\$215.00	\$75.000	\$220.00	\$280.000
Extended Price	3,311.04	3,440.00	1,200.00	3,520.00	4,480.00

Line 16 Gabion Mattresses (Galvanized) (12 IN) (TxDOT Item No 459) installed complete, per specifications 111 sy									
Unit Price	\$46.130	\$170.00	\$80.000	\$75.00	8,325.00	\$158.000			
Extended Price	5,120.43	18,870.00	8,880.00						17,538.00

Line 17 Gabions (3'x3')(Galvanized), (TxDOT Item No 459) installed complete, per specifications 5 cy									
Unit Price	\$115.000	\$490.00	\$200.000	\$385.00	1,925.00	\$295.000			
Extended Price	575.00	2,450.00	1,000.00						1,475.00

Line 18 Conc Box Culv (6FT x 5 FT) complete, per specifications 480 lf									
Unit Price	\$437.870	\$547.00	\$365.000	\$558.30	267,984.00	\$520.000			
Extended Price	210,177.60	262,560.00	175,200.00						249,600.00

Line 19 Conc Box Culv (8 FT x 6 FT) complete, per specifications 870 lf									
Unit Price	\$654.140	\$750.00	\$595.000	\$740.00	643,800.00	\$715.000			
Extended Price	569,101.80	652,500.00	517,650.00						622,050.00

Line 20 RC PIPE (CL III)(36 IN) installed complete, per specifications 72 lf									
Unit Price	\$174.170	\$217.00	\$80.000	\$131.00	9,432.00	\$216.000			
Extended Price	12,540.24	15,624.00	5,760.00						15,552.00



Bid No. 5714 Arden Road Storm Sewer and Playa #7 Excavation- Phase 1  
 Opened 4:00 p.m., April 27, 2017

To be awarded by line item	Williams Ditching LLC	Holmes Construction Company	Spiess Construction Co Inc	L A Fuller & Sons Construction Ltd	D E Rice Construction Company Inc
Line 1 Construction Item - Layout and Survey to include slope staking, construction staking and other associated staking (COA 10.06) complete, per specifications					
1 ls					
Unit Price	\$120,293.000	\$17,200.00	\$30,000.000	\$41,630.00	\$40,000.000
Extended Price	120,293.00	17,200.00	30,000.00	41,630.00	40,000.00
Line 2 Excavation, regrading and channel grading to the slopes shown on the plans, (COA 4.02) complete, per specifications					
253,000 cy					
Unit Price	\$4.070	\$6.55	\$10.000	\$8.05	\$8.000
Extended Price	1,029,710.00	1,657,150.00	2,530,000.00	2,036,650.00	2,024,000.00
Line 3 Trenching, supplying, laying, joining, and backfilling for sixty inch (60") HDPE storm sewer, (COA 5.052) installed complete, per specifications					
80 lf					
Unit Price	\$164.530	\$323.00	\$100.000	\$199.00	\$325.000
Extended Price	13,162.40	25,840.00	8,000.00	15,920.00	26,000.00



To be awarded by line item	Williams Ditching LLC	Holmes Construction Company	Spieess Construction Co Inc	L A Fuller & Sons Construction Ltd	D E Rice Construction Company Inc
Line 4 Furnish, install and maintain Traffic control Plan, (COA 9.04) complete, per specifications					
1 ls	\$9,623.000	\$36,450.00	\$75,000.000	\$49,000.00	\$10,000.000
Unit Price					
Extended Price	9,623.00	36,450.00	75,000.00	49,000.00	10,000.00
Line 5 Mobilization / Demobilization including Insurance, Payment Bond, Performance Bond, Maintenance Bond and related Ancillary Costs. (Shall not exceed five percent (5%) of the total construction cost(COA 10.01), per specifications					
1 ls	\$104,949.860	\$131,100.00	\$175,000.000	\$128,040.00	\$65,300.000
Unit Price					
Extended Price	104,949.86	131,100.00	175,000.00	128,040.00	65,300.00
Line 6 Remove Stab Base & Asph Pav (8" - 20"), complete, per specifications					
145 sy	\$7.380	\$52.00	\$20.000	\$24.00	\$35.000
Unit Price					
Extended Price	1,070.10	7,540.00	2,900.00	3,480.00	5,075.00

To be awarded by line item	Williams Ditching LLC	Holmes Construction Company	Spiess Construction Co Inc	L A Fuller & Sons Construction	D E Rice Construction Company
Line 7 Furnish, haul, place and compact new fill, select material (Pl<15). Material is to be placed in lifts not to exceed six inches (6") and compacted to 95% Proctor, (TxDOT Item No 132), complete , per specifications					
28 cy					
Unit Price	\$94.290	\$201.00	\$50.000	\$115.00	\$150.000
Extended Price	2,640.12	5,628.00	1,400.00	3,220.00	4,200.00
Line 8 Drill Seed (Perm)(Urban)(Clay), complete, per specifications					
115,000 sy					
Unit Price	\$0.120	\$0.60	\$0.500	\$0.65	\$0.150
Extended Price	13,800.00	69,000.00	57,500.00	74,750.00	17,250.00
Line 9 Sediment control, Soil Retention Blanket, (Flexible Channel Liner) (Class 2 Type F), (TxDOT Item No 169) installed complete per specifications					
31,000 sy					
Unit Price	\$0.770	\$0.76	\$0.500	\$1.20	\$2.000
Extended Price	23,870.00	23,560.00	15,500.00	37,200.00	62,000.00
Line 10 FL BS (CMP in PLC)(TY A or B)(GR 4)(12") complete, per specifications					
145 sy					
Unit Price	\$31.760	\$83.45	\$15.000	\$38.00	\$66.000
Extended Price	4,605.20	12,100.25	2,175.00	5,510.00	9,570.00

To be awarded by line item	Williams Ditching LLC	Holmes Construction Company	Spieess Construction Co Inc	L A Fuller & Sons Construction Ltd	D E Rice Construction Company Inc
Line 11 D-GR HMA (SQ) TY-B PG64-22, (TxDOT Item No 3267) complete per specifications					
34 Ton					
Unit Price	\$104.060	\$302.00	\$100.000	\$443.00	\$220.000
Extended Price	3,538.04	10,268.00	3,400.00	15,062.00	7,480.00
Line 12 D-GR HMA (SQ) Ty-D PG64-22, (TxDOT Item No 3267) complete, per specifications					
17 Ton					
Unit Price	\$270.060	\$300.00	\$100.000	\$670.00	\$440.000
Extended Price	4,591.02	5,100.00	1,700.00	11,390.00	7,480.00
Line 13 Trench Excavation Protection, complete, per specifications					
1,531 LF					
Unit Price	\$12.920	\$9.75	\$1.000	\$27.00	\$10.000
Extended Price	19,780.52	14,927.25	1,531.00	41,337.00	15,310.00
Line 14 RIPRAP (Conc)(4IN) complete, per specifications					
40 CY					
Unit Price	\$226.500	\$495.00	\$500.000	\$612.00	\$105.000
Extended Price	9,060.00	19,800.00	20,000.00	24,480.00	4,200.00
Line 15 RIPRAP (Stone Common (Dry))(18 IN) complete, per specifications					
16 CY					
Unit Price	\$206.940	\$215.00	\$75.000	\$220.00	\$280.000
Extended Price	3,311.04	3,440.00	1,200.00	3,520.00	4,480.00

To be awarded by line item	Williams Ditching LLC	Holmes Construction Company	Spiess Construction Co Inc	Ltd	Inc
Line 16 Gabion Mattresses (Galvanized) (12 IN) (TxDOT Item No 459) installed complete, per specifications 111 sy					
Unit Price	\$46.130	\$170.00	\$80.000	\$75.00	\$158.000
Extended Price	5,120.43	18,870.00	8,880.00	8,325.00	17,538.00
Line 17 Gabions (3'x3')(Galvanized), (TxDOT Item No 459) installed complete, per specifications 5 cy					
Unit Price	\$115.000	\$490.00	\$200.000	\$385.00	\$295.000
Extended Price	575.00	2,450.00	1,000.00	1,925.00	1,475.00
Line 18 Conc Box Culv (6FT x 5 FT) complete, per specifications 480 lf					
Unit Price	\$437.870	\$547.00	\$365.000	\$558.30	\$520.000
Extended Price	210,177.60	262,560.00	175,200.00	267,984.00	249,600.00
Line 19 Conc Box Culv (8 FT x 6 FT) complete, per specifications 870 lf					
Unit Price	\$654.140	\$750.00	\$595.000	\$740.00	\$715.000
Extended Price	569,101.80	652,500.00	517,650.00	643,800.00	622,050.00
Line 20 RC PIPE (CL III)(36 IN) installed complete, per specifications 72 lf					
Unit Price	\$174.170	\$217.00	\$80.000	\$131.00	\$216.000
Extended Price	12,540.24	15,624.00	5,760.00	9,432.00	15,552.00



To be awarded by line item	Williams Ditching LLC	Holmes Construction Company	Spieess Construction Co Inc	L A Fuller & Sons Construction Ltd	D E Rice Construction Company Inc
Line 4 Furnish, install and maintain Traffic control Plan, (COA 9.04) complete, per specifications					
1 ls	\$9,623.000	\$36,450.00	\$75,000.000	\$49,000.00	\$10,000.000
Unit Price					
Extended Price	9,623.00	36,450.00	75,000.00	49,000.00	10,000.00
Line 5 Mobilization / Demobilization including Insurance, Payment Bond, Performance Bond, Maintenance Bond and related Ancillary Costs. (Shall not exceed five percent (5%) of the total construction cost(COA 10.01), per specifications					
1 ls	\$104,949.860	\$131,100.00	\$175,000.000	\$128,040.00	\$65,300.000
Unit Price					
Extended Price	104,949.86	131,100.00	175,000.00	128,040.00	65,300.00
Line 6 Remove Stab Base & Asph Pav (8" - 20"), complete, per specifications					
145 sy	\$7.380	\$52.00	\$20.000	\$24.00	\$35.000
Unit Price					
Extended Price	1,070.10	7,540.00	2,900.00	3,480.00	5,075.00

To be awarded by line item	Williams Ditching LLC	Holmes Construction Company	Spiess Construction Co Inc	L A Fuller & Sons Construction	D E Rice Construction Company
Line 7 Furnish, haul, place and compact new fill, select material (Pl<15). Material is to be placed in lifts not to exceed six inches (6") and compacted to 95% Proctor, (TxDOT Item No 132), complete , per specifications					
28 cy					
Unit Price	\$94.290	\$201.00	\$50.000	\$115.00	\$150.000
Extended Price	2,640.12	5,628.00	1,400.00	3,220.00	4,200.00
Line 8 Drill Seed (Perm)(Urban)(Clay), complete, per specifications					
115,000 sy					
Unit Price	\$0.120	\$0.60	\$0.500	\$0.65	\$0.150
Extended Price	13,800.00	69,000.00	57,500.00	74,750.00	17,250.00
Line 9 Sediment control, Soil Retention Blanket, (Flexible Channel Liner) (Class 2 Type F), (TxDOT Item No 169) installed complete per specifications					
31,000 sy					
Unit Price	\$0.770	\$0.76	\$0.500	\$1.20	\$2.000
Extended Price	23,870.00	23,560.00	15,500.00	37,200.00	62,000.00
Line 10 FL BS (CMP in PLC)(TY A or B)(GR 4)(12") complete, per specifications					
145 sy					
Unit Price	\$31.760	\$83.45	\$15.000	\$38.00	\$66.000
Extended Price	4,605.20	12,100.25	2,175.00	5,510.00	9,570.00

To be awarded by line item	Williams Ditching LLC	Holmes Construction Company	Spieess Construction Co Inc	Ltd	Inc
Line11 D-GR HMA (SQ) TY-B PG64-22, (TxDOT Item No 3267) complete per specifications					
34 Ton					
Unit Price	\$104.060	\$302.00	\$100.000	\$443.00	\$220.000
Extended Price	3,538.04	10,268.00	3,400.00	15,062.00	7,480.00
Line 12 D-GR HMA (SQ) Ty-D PG64-22, )TxDOT Item No 3267) complete, per specifications					
17 Ton					
Unit Price	\$270.060	\$300.00	\$100.000	\$670.00	\$440.000
Extended Price	4,591.02	5,100.00	1,700.00	11,390.00	7,480.00
Line 13 Trench Excavation Protection, compele, per specifications					
1,531 LF					
Unit Price	\$12.920	\$9.75	\$1.000	\$27.00	\$10.000
Extended Price	19,780.52	14,927.25	1,531.00	41,337.00	15,310.00
Line 14 RIPRAP (Conc)(4IN) complete, per specifications					
40 CY					
Unit Price	\$226.500	\$495.00	\$500.000	\$612.00	\$105.000
Extended Price	9,060.00	19,800.00	20,000.00	24,480.00	4,200.00
Line 15 RIPRAP (Stone Common (Dry)(18 IN) complete, per specifications					
16 CY					
Unit Price	\$206.940	\$215.00	\$75.000	\$220.00	\$280.000
Extended Price	3,311.04	3,440.00	1,200.00	3,520.00	4,480.00



To be awarded by line item	Williams Ditching LLC	Holmes Construction Company	Spiess Construction Co Inc	Ltd	Inc
Line 16 Gabion Mattresses (Galvanized) (12 IN) (TxDOT Item No 459) installed complete, per specifications 111 sy					
Unit Price	\$46.130	\$170.00	\$80.000	\$75.00	\$158.000
Extended Price	5,120.43	18,870.00	8,880.00	8,325.00	17,538.00
Line 17 Gabions (3'x3')(Galvanized), (TxDOT Item No 459) installed complete, per specifications 5 cy					
Unit Price	\$115.000	\$490.00	\$200.000	\$385.00	\$295.000
Extended Price	575.00	2,450.00	1,000.00	1,925.00	1,475.00
Line 18 Conc Box Culv (6FT x 5 FT) complete, per specifications 480 lf					
Unit Price	\$437.870	\$547.00	\$365.000	\$558.30	\$520.000
Extended Price	210,177.60	262,560.00	175,200.00	267,984.00	249,600.00
Line 19 Conc Box Culv (8 FT x 6 FT) complete, per specifications 870 lf					
Unit Price	\$654.140	\$750.00	\$595.000	\$740.00	\$715.000
Extended Price	569,101.80	652,500.00	517,650.00	643,800.00	622,050.00
Line 20 RC PIPE (CL III)(36 IN) installed complete, per specifications 72 lf					
Unit Price	\$174.170	\$217.00	\$80.000	\$131.00	\$216.000
Extended Price	12,540.24	15,624.00	5,760.00	9,432.00	15,552.00

To be awarded by line item Williams Ditching LLC Holmes Construction Company Spiess Construction Co Inc L A Fuller & Sons Construction D E Rice Construction Company Inc

Line 21 RC Pipe (CL III)(42 IN)( TxDOT Item No 464) installed complete, per specifications 72 lf									
Unit Price	\$220.740	\$260.00	\$110.000	\$175.00	\$258.000				
Extended Price	15,893.28	18,720.00	7,920.00	12,600.00	18,576.00				

Line 22 Manhole (complete) (Junction Box) (Type 1) (TxDOT Item 465) installed complete, per specifications 1 ea									
Unit Price	\$10,335.000	\$8,175.00	\$25,000.000	\$13,541.00	\$8,225.000				
Extended Price	10,335.00	8,175.00	25,000.00	13,541.00	8,225.00				

Line 23 Inlet (compl)(PADZ) (FG)(4 FT x 4 FT - 3 FT x 3 FT) complete per specifications 2 ea									
Unit Price	\$5,660.000	\$4,625.00	\$7,500.000	\$4,961.00	\$4,360.000				
Extended Price	11,320.00	9,250.00	15,000.00	9,922.00	8,720.00				

Line 24 Wingwall (SW-0)(HW=14 ft)(Mod)(TxDOT Item No 466) installed complete, per specifications 1 ea									
Unit Price	\$18,240.000	\$32,550.00	\$12,000.000	\$35,387.00	\$28,065.000				
Extended Price	18,240.00	32,550.00	12,000.00	35,387.00	28,065.00				

To be awarded by line item	Williams Ditching LLC	Holmes Construction Company	Spieess Construction Co Inc	L A Fuller & Sons Construction Ltd	D E Rice Construction Company Inc
Line 4 Furnish, install and maintain Traffic control Plan, (COA 9.04) complete, per specifications					
1 ls	\$9,623.000	\$36,450.00	\$75,000.000	\$49,000.00	\$10,000.000
Unit Price					
Extended Price	9,623.00	36,450.00	75,000.00	49,000.00	10,000.00
Line 5 Mobilization / Demobilization including Insurance, Payment Bond, Performance Bond, Maintenance Bond and related Ancillary Costs. (Shall not exceed five percent (5%) of the total construction cost(COA 10.01), per specifications					
1 ls	\$104,949.860	\$131,100.00	\$175,000.000	\$128,040.00	\$65,300.000
Unit Price					
Extended Price	104,949.86	131,100.00	175,000.00	128,040.00	65,300.00
Line 6 Remove Stab Base & Asph Pav (8" - 20"), complete, per specifications					
145 sy	\$7.380	\$52.00	\$20.000	\$24.00	\$35.000
Unit Price					
Extended Price	1,070.10	7,540.00	2,900.00	3,480.00	5,075.00

To be awarded by line item	Williams Ditching LLC	Holmes Construction Company	Spiess Construction Co Inc	L A Fuller & Sons Construction	D E Rice Construction Company
Line 7 Furnish, haul, place and compact new fill, select material (Pl<15). Material is to be placed in lifts not to exceed six inches (6") and compacted to 95% Proctor, (TxDOT Item No 132), complete , per specifications					
28 cy					
Unit Price	\$94.290	\$201.00	\$50.000	\$115.00	\$150.000
Extended Price	2,640.12	5,628.00	1,400.00	3,220.00	4,200.00
Line 8 Drill Seed (Perm)(Urban)(Clay), complete, per specifications					
115,000 sy					
Unit Price	\$0.120	\$0.60	\$0.500	\$0.65	\$0.150
Extended Price	13,800.00	69,000.00	57,500.00	74,750.00	17,250.00
Line 9 Sediment control, Soil Retention Blanket, (Flexible Channel Liner) (Class 2 Type F), (TxDOT Item No 169) installed complete per specifications					
31,000 sy					
Unit Price	\$0.770	\$0.76	\$0.500	\$1.20	\$2.000
Extended Price	23,870.00	23,560.00	15,500.00	37,200.00	62,000.00
Line 10 FL BS (CMP in PLC)(TY A or B)(GR 4)(12") complete, per specifications					
145 sy					
Unit Price	\$31.760	\$83.45	\$15.000	\$38.00	\$66.000
Extended Price	4,605.20	12,100.25	2,175.00	5,510.00	9,570.00

To be awarded by line item	Williams Ditching LLC	Holmes Construction Company	Spieess Construction Co Inc	L A Fuller & Sons Construction Ltd	D E Rice Construction Company Inc
Line 4 Furnish, install and maintain Traffic control Plan, (COA 9.04) complete, per specifications					
1 ls	\$9,623.000	\$36,450.00	\$75,000.000	\$49,000.00	\$10,000.000
Unit Price					
Extended Price	9,623.00	36,450.00	75,000.00	49,000.00	10,000.00
Line 5 Mobilization / Demobilization including Insurance, Payment Bond, Performance Bond, Maintenance Bond and related Ancillary Costs. (Shall not exceed five percent (5%) of the total construction cost(COA 10.01), per specifications					
1 ls	\$104,949.860	\$131,100.00	\$175,000.000	\$128,040.00	\$65,300.000
Unit Price					
Extended Price	104,949.86	131,100.00	175,000.00	128,040.00	65,300.00
Line 6 Remove Stab Base & Asph Pav (8" - 20"), complete, per specifications					
145 sy	\$7.380	\$52.00	\$20.000	\$24.00	\$35.000
Unit Price					
Extended Price	1,070.10	7,540.00	2,900.00	3,480.00	5,075.00

To be awarded by line item	Williams Ditching LLC	Holmes Construction Company	Spiess Construction Co Inc	L A Fuller & Sons Construction	D E Rice Construction Company
Line 7 Furnish, haul, place and compact new fill, select material (Pl<15). Material is to be placed in lifts not to exceed six inches (6") and compacted to 95% Proctor, (TxDOT Item No 132), complete , per specifications					
28 cy					
Unit Price	\$94.290	\$201.00	\$50.000	\$115.00	\$150.000
Extended Price	2,640.12	5,628.00	1,400.00	3,220.00	4,200.00
Line 8 Drill Seed (Perm)(Urban)(Clay), complete, per specifications					
115,000 sy					
Unit Price	\$0.120	\$0.60	\$0.500	\$0.65	\$0.150
Extended Price	13,800.00	69,000.00	57,500.00	74,750.00	17,250.00
Line 9 Sediment control, Soil Retention Blanket, (Flexible Channel Liner) (Class 2 Type F), (TxDOT Item No 169) installed complete per specifications					
31,000 sy					
Unit Price	\$0.770	\$0.76	\$0.500	\$1.20	\$2.000
Extended Price	23,870.00	23,560.00	15,500.00	37,200.00	62,000.00
Line 10 FL BS (CMP in PLC)(TY A or B)(GR 4)(12") complete, per specifications					
145 sy					
Unit Price	\$31.760	\$83.45	\$15.000	\$38.00	\$66.000
Extended Price	4,605.20	12,100.25	2,175.00	5,510.00	9,570.00

To be awarded by line item	Williams Ditching LLC	Holmes Construction Company	Spieess Construction Co Inc	L A Fuller & Sons Construction Ltd	D E Rice Construction Company Inc
Line 11 D-GR HMA (SQ) TY-B PG64-22, (TxDOT Item No 3267) complete per specifications					
34 Ton					
Unit Price	\$104.060	\$302.00	\$100.000	\$443.00	\$220.000
Extended Price	3,538.04	10,268.00	3,400.00	15,062.00	7,480.00
Line 12 D-GR HMA (SQ) Ty-D PG64-22, (TxDOT Item No 3267) complete, per specifications					
17 Ton					
Unit Price	\$270.060	\$300.00	\$100.000	\$670.00	\$440.000
Extended Price	4,591.02	5,100.00	1,700.00	11,390.00	7,480.00
Line 13 Trench Excavation Protection, comple, per specifications					
1,531 LF					
Unit Price	\$12.920	\$9.75	\$1.000	\$27.00	\$10.000
Extended Price	19,780.52	14,927.25	1,531.00	41,337.00	15,310.00
Line 14 RIPRAP (Conc)(4IN) complete, per specifications					
40 CY					
Unit Price	\$226.500	\$495.00	\$500.000	\$612.00	\$105.000
Extended Price	9,060.00	19,800.00	20,000.00	24,480.00	4,200.00
Line 15 RIPRAP (Stone Common (Dry))(18 IN) complete, per specifications					
16 CY					
Unit Price	\$206.940	\$215.00	\$75.000	\$220.00	\$280.000
Extended Price	3,311.04	3,440.00	1,200.00	3,520.00	4,480.00

To be awarded by line item	Williams Ditching LLC	Holmes Construction Company	Spieess Construction Co Inc	L A Fuller & Sons Construction Ltd	D E Rice Construction Company Inc
Line 4 Furnish, install and maintain Traffic control Plan, (COA 9.04) complete, per specifications					
1 ls	\$9,623.000	\$36,450.00	\$75,000.000	\$49,000.00	\$10,000.000
Unit Price					
Extended Price	9,623.00	36,450.00	75,000.00	49,000.00	10,000.00
Line 5 Mobilization / Demobilization including Insurance, Payment Bond, Performance Bond, Maintenance Bond and related Ancillary Costs. (Shall not exceed five percent (5%) of the total construction cost(COA 10.01), per specifications					
1 ls	\$104,949.860	\$131,100.00	\$175,000.000	\$128,040.00	\$65,300.000
Unit Price					
Extended Price	104,949.86	131,100.00	175,000.00	128,040.00	65,300.00
Line 6 Remove Stab Base & Asph Pav (8" - 20"), complete, per specifications					
145 sy	\$7.380	\$52.00	\$20.000	\$24.00	\$35.000
Unit Price					
Extended Price	1,070.10	7,540.00	2,900.00	3,480.00	5,075.00



To be awarded by line item	Williams Ditching LLC	Holmes Construction Company	Spiess Construction Co Inc	L A Fuller & Sons Construction	D E Rice Construction Company
Line 7 Furnish, haul, place and compact new fill, select material (Pl<15). Material is to be placed in lifts not to exceed six inches (6") and compacted to 95% Proctor, (TxDOT Item No 132), complete , per specifications					
28 cy					
Unit Price	\$94.290	\$201.00	\$50.000	\$115.00	\$150.000
Extended Price	2,640.12	5,628.00	1,400.00	3,220.00	4,200.00
Line 8 Drill Seed (Perm)(Urban)(Clay), complete, per specifications					
115,000 sy					
Unit Price	\$0.120	\$0.60	\$0.500	\$0.65	\$0.150
Extended Price	13,800.00	69,000.00	57,500.00	74,750.00	17,250.00
Line 9 Sediment control, Soil Retention Blanket, (Flexible Channel Liner) (Class 2 Type F), (TxDOT Item No 169) installed complete per specifications					
31,000 sy					
Unit Price	\$0.770	\$0.76	\$0.500	\$1.20	\$2.000
Extended Price	23,870.00	23,560.00	15,500.00	37,200.00	62,000.00
Line 10 FL BS (CMP in PLC)(TY A or B)(GR 4)(12") complete, per specifications					
145 sy					
Unit Price	\$31.760	\$83.45	\$15.000	\$38.00	\$66.000
Extended Price	4,605.20	12,100.25	2,175.00	5,510.00	9,570.00

To be awarded by line item	Williams Ditching LLC	Holmes Construction Company	Spieess Construction Co Inc	L A Fuller & Sons Construction Ltd	D E Rice Construction Company Inc
Line 4 Furnish, install and maintain Traffic control Plan, (COA 9.04) complete, per specifications					
1 ls	\$9,623.000	\$36,450.00	\$75,000.000	\$49,000.00	\$10,000.000
Unit Price					
Extended Price	9,623.00	36,450.00	75,000.00	49,000.00	10,000.00
Line 5 Mobilization / Demobilization including Insurance, Payment Bond, Performance Bond, Maintenance Bond and related Ancillary Costs. (Shall not exceed five percent (5%) of the total construction cost(COA 10.01), per specifications					
1 ls	\$104,949.860	\$131,100.00	\$175,000.000	\$128,040.00	\$65,300.000
Unit Price					
Extended Price	104,949.86	131,100.00	175,000.00	128,040.00	65,300.00
Line 6 Remove Stab Base & Asph Pav (8" - 20"), complete, per specifications					
145 sy	\$7.380	\$52.00	\$20.000	\$24.00	\$35.000
Unit Price					
Extended Price	1,070.10	7,540.00	2,900.00	3,480.00	5,075.00

To be awarded by line item	Williams Ditching LLC	Holmes Construction Company	Spiess Construction Co Inc	L A Fuller & Sons Construction	D E Rice Construction Company
Line 7 Furnish, haul, place and compact new fill, select material (Pl<15). Material is to be placed in lifts not to exceed six inches (6") and compacted to 95% Proctor, (TxDOT Item No 132), complete , per specifications					
28 cy					
Unit Price	\$94.290	\$201.00	\$50.000	\$115.00	\$150.000
Extended Price	2,640.12	5,628.00	1,400.00	3,220.00	4,200.00
Line 8 Drill Seed (Perm)(Urban)(Clay), complete, per specifications					
115,000 sy					
Unit Price	\$0.120	\$0.60	\$0.500	\$0.65	\$0.150
Extended Price	13,800.00	69,000.00	57,500.00	74,750.00	17,250.00
Line 9 Sediment control, Soil Retention Blanket, (Flexible Channel Liner) (Class 2 Type F), (TxDOT Item No 169) installed complete per specifications					
31,000 sy					
Unit Price	\$0.770	\$0.76	\$0.500	\$1.20	\$2.000
Extended Price	23,870.00	23,560.00	15,500.00	37,200.00	62,000.00
Line 10 FL BS (CMP in PLC)(TY A or B)(GR 4)(12") complete, per specifications					
145 sy					
Unit Price	\$31.760	\$83.45	\$15.000	\$38.00	\$66.000
Extended Price	4,605.20	12,100.25	2,175.00	5,510.00	9,570.00

To be awarded by line item	Williams Ditching LLC	Holmes Construction Company	Spieess Construction Co Inc	Ltd	Inc
Line11 D-GR HMA (SQ) TY-B PG64-22, (TxDOT Item No 3267) complete per specifications					
34 Ton					
Unit Price	\$104.060	\$302.00	\$100.000	\$443.00	\$220.000
Extended Price	3,538.04	10,268.00	3,400.00	15,062.00	7,480.00
Line 12 D-GR HMA (SQ) Ty-D PG64-22, )TxDOT Item No 3267) complete, per specifications					
17 Ton					
Unit Price	\$270.060	\$300.00	\$100.000	\$670.00	\$440.000
Extended Price	4,591.02	5,100.00	1,700.00	11,390.00	7,480.00
Line 13 Trench Excavation Protection, compele, per specifications					
1,531 LF					
Unit Price	\$12.920	\$9.75	\$1.000	\$27.00	\$10.000
Extended Price	19,780.52	14,927.25	1,531.00	41,337.00	15,310.00
Line 14 RIPRAP (Conc)(4IN) complete, per specifications					
40 CY					
Unit Price	\$226.500	\$495.00	\$500.000	\$612.00	\$105.000
Extended Price	9,060.00	19,800.00	20,000.00	24,480.00	4,200.00
Line 15 RIPRAP (Stone Common (Dry)(18 IN) complete, per specifications					
16 CY					
Unit Price	\$206.940	\$215.00	\$75.000	\$220.00	\$280.000
Extended Price	3,311.04	3,440.00	1,200.00	3,520.00	4,480.00

To be awarded by line item	Williams Ditching LLC	Holmes Construction Company	Spiess Construction Co Inc	Ltd	Inc
Line 16 Gabion Mattresses (Galvanized) (12 IN) (TxDOT Item No 459) installed complete, per specifications 111 sy					
Unit Price	\$46.130	\$170.00	\$80.000	\$75.00	\$158.000
Extended Price	5,120.43	18,870.00	8,880.00	8,325.00	17,538.00
Line 17 Gabions (3'x3')(Galvanized), (TxDOT Item No 459) installed complete, per specifications 5 cy					
Unit Price	\$115.000	\$490.00	\$200.000	\$385.00	\$295.000
Extended Price	575.00	2,450.00	1,000.00	1,925.00	1,475.00
Line 18 Conc Box Culv (6FT x 5 FT) complete, per specifications 480 lf					
Unit Price	\$437.870	\$547.00	\$365.000	\$558.30	\$520.000
Extended Price	210,177.60	262,560.00	175,200.00	267,984.00	249,600.00
Line 19 Conc Box Culv (8 FT x 6 FT) complete, per specifications 870 lf					
Unit Price	\$654.140	\$750.00	\$595.000	\$740.00	\$715.000
Extended Price	569,101.80	652,500.00	517,650.00	643,800.00	622,050.00
Line 20 RC PIPE (CL III)(36 IN) installed complete, per specifications 72 lf					
Unit Price	\$174.170	\$217.00	\$80.000	\$131.00	\$216.000
Extended Price	12,540.24	15,624.00	5,760.00	9,432.00	15,552.00

To be awarded by line item Williams Ditching LLC Holmes Construction Company Spiess Construction Co Inc L A Fuller & Sons Construction D E Rice Construction Company Inc

Line 21 RC Pipe (CL III)(42 IN)( TxDOT Item No 464) installed complete, per specifications 72 lf									
Unit Price	\$220.740	\$260.00	\$110.000	\$175.00	\$258.000				
Extended Price	15,893.28	18,720.00	7,920.00	12,600.00	18,576.00				

Line 22 Manhole (complete) (Junction Box) (Type 1) (TxDOT Item 465) installed complete, per specifications 1 ea									
Unit Price	\$10,335.000	\$8,175.00	\$25,000.000	\$13,541.00	\$8,225.000				
Extended Price	10,335.00	8,175.00	25,000.00	13,541.00	8,225.00				

Line 23 Inlet (compl)(PADZ) (FG)(4 FT x 4 FT - 3 FT x 3 FT) complete per specifications 2 ea									
Unit Price	\$5,660.000	\$4,625.00	\$7,500.000	\$4,961.00	\$4,360.000				
Extended Price	11,320.00	9,250.00	15,000.00	9,922.00	8,720.00				

Line 24 Wingwall (SW-0)(HW=14 ft)(Mod)(TxDOT Item No 466) installed complete, per specifications 1 ea									
Unit Price	\$18,240.000	\$32,550.00	\$12,000.000	\$35,387.00	\$28,065.000				
Extended Price	18,240.00	32,550.00	12,000.00	35,387.00	28,065.00				

To be awarded by line item	Williams Ditching LLC	Holmes Construction Company	Spieess Construction Co Inc	L A Fuller & Sons Construction Ltd	D E Rice Construction Company Inc
Line 4 Furnish, install and maintain Traffic control Plan, (COA 9.04) complete, per specifications					
1 ls	\$9,623.000	\$36,450.00	\$75,000.000	\$49,000.00	\$10,000.000
Unit Price					
Extended Price	9,623.00	36,450.00	75,000.00	49,000.00	10,000.00
Line 5 Mobilization / Demobilization including Insurance, Payment Bond, Performance Bond, Maintenance Bond and related Ancillary Costs. (Shall not exceed five percent (5%) of the total construction cost(COA 10.01), per specifications					
1 ls	\$104,949.860	\$131,100.00	\$175,000.000	\$128,040.00	\$65,300.000
Unit Price					
Extended Price	104,949.86	131,100.00	175,000.00	128,040.00	65,300.00
Line 6 Remove Stab Base & Asph Pav (8" - 20"), complete, per specifications					
145 sy	\$7.380	\$52.00	\$20.000	\$24.00	\$35.000
Unit Price					
Extended Price	1,070.10	7,540.00	2,900.00	3,480.00	5,075.00

To be awarded by line item	Williams Ditching LLC	Holmes Construction Company	Spiess Construction Co Inc	L A Fuller & Sons Construction	D E Rice Construction Company
Line 7 Furnish, haul, place and compact new fill, select material (Pl<15). Material is to be placed in lifts not to exceed six inches (6") and compacted to 95% Proctor, (TxDOT Item No 132), complete , per specifications					
28 cy					
Unit Price	\$94.290	\$201.00	\$50.000	\$115.00	\$150.000
Extended Price	2,640.12	5,628.00	1,400.00	3,220.00	4,200.00
Line 8 Drill Seed (Perm)(Urban)(Clay), complete, per specifications					
115,000 sy					
Unit Price	\$0.120	\$0.60	\$0.500	\$0.65	\$0.150
Extended Price	13,800.00	69,000.00	57,500.00	74,750.00	17,250.00
Line 9 Sediment control, Soil Retention Blanket, (Flexible Channel Liner) (Class 2 Type F), (TxDOT Item No 169) installed complete per specifications					
31,000 sy					
Unit Price	\$0.770	\$0.76	\$0.500	\$1.20	\$2.000
Extended Price	23,870.00	23,560.00	15,500.00	37,200.00	62,000.00
Line 10 FL BS (CMP in PLC)(TY A or B)(GR 4)(12") complete, per specifications					
145 sy					
Unit Price	\$31.760	\$83.45	\$15.000	\$38.00	\$66.000
Extended Price	4,605.20	12,100.25	2,175.00	5,510.00	9,570.00



To be awarded by line item	Williams Ditching LLC	Holmes Construction Company	Spieess Construction Co Inc	Ltd	Inc
Line11 D-GR HMA (SQ) TY-B PG64-22, (TxDOT Item No 3267) complete per specifications					
34 Ton					
Unit Price	\$104.060	\$302.00	\$100.000	\$443.00	\$220.000
Extended Price	3,538.04	10,268.00	3,400.00	15,062.00	7,480.00
Line 12 D-GR HMA (SQ) Ty-D PG64-22, )TxDOT Item No 3267) complete, per specifications					
17 Ton					
Unit Price	\$270.060	\$300.00	\$100.000	\$670.00	\$440.000
Extended Price	4,591.02	5,100.00	1,700.00	11,390.00	7,480.00
Line 13 Trench Excavation Protection, compele, per specifications					
1,531 LF					
Unit Price	\$12.920	\$9.75	\$1.000	\$27.00	\$10.000
Extended Price	19,780.52	14,927.25	1,531.00	41,337.00	15,310.00
Line 14 RIPRAP (Conc)(4IN) complete, per specifications					
40 CY					
Unit Price	\$226.500	\$495.00	\$500.000	\$612.00	\$105.000
Extended Price	9,060.00	19,800.00	20,000.00	24,480.00	4,200.00
Line 15 RIPRAP (Stone Common (Dry)(18 IN) complete, per specifications					
16 CY					
Unit Price	\$206.940	\$215.00	\$75.000	\$220.00	\$280.000
Extended Price	3,311.04	3,440.00	1,200.00	3,520.00	4,480.00

To be awarded by line item	Williams Ditching LLC	Holmes Construction Company	Spieess Construction Co Inc	Ltd	Inc
Line 11 D-GR HMA (SQ) TY-B PG64-22, (TxDOT Item No 3267) complete per specifications					
34 Ton					
Unit Price	\$104.060	\$302.00	\$100.000	\$443.00	\$220.000
Extended Price	3,538.04	10,268.00	3,400.00	15,062.00	7,480.00
Line 12 D-GR HMA (SQ) Ty-D PG64-22, )TxDOT Item No 3267) complete, per specifications					
17 Ton					
Unit Price	\$270.060	\$300.00	\$100.000	\$670.00	\$440.000
Extended Price	4,591.02	5,100.00	1,700.00	11,390.00	7,480.00
Line 13 Trench Excavation Protection, compele, per specifications					
1,531 LF					
Unit Price	\$12.920	\$9.75	\$1.000	\$27.00	\$10.000
Extended Price	19,780.52	14,927.25	1,531.00	41,337.00	15,310.00
Line 14 RIPRAP (Conc)(4IN) complete, per specifications					
40 CY					
Unit Price	\$226.500	\$495.00	\$500.000	\$612.00	\$105.000
Extended Price	9,060.00	19,800.00	20,000.00	24,480.00	4,200.00
Line 15 RIPRAP (Stone Common (Dry))(18 IN) complete, per specifications					
16 CY					
Unit Price	\$206.940	\$215.00	\$75.000	\$220.00	\$280.000
Extended Price	3,311.04	3,440.00	1,200.00	3,520.00	4,480.00

To be awarded by line item	Williams Ditching LLC	Holmes Construction Company	Spiess Construction Co Inc	Ltd	Inc
Line 16 Gabion Mattresses (Galvanized) (12 IN) (TxDOT Item No 459) installed complete, per specifications 111 sy					
Unit Price	\$46.130	\$170.00	\$80.000	\$75.00	\$158.000
Extended Price	5,120.43	18,870.00	8,880.00	8,325.00	17,538.00
Line 17 Gabions (3'x3')(Galvanized), (TxDOT Item No 459) installed complete, per specifications 5 cy					
Unit Price	\$115.000	\$490.00	\$200.000	\$385.00	\$295.000
Extended Price	575.00	2,450.00	1,000.00	1,925.00	1,475.00
Line 18 Conc Box Culv (6FT x 5 FT) complete, per specifications 480 lf					
Unit Price	\$437.870	\$547.00	\$365.000	\$558.30	\$520.000
Extended Price	210,177.60	262,560.00	175,200.00	267,984.00	249,600.00
Line 19 Conc Box Culv (8 FT x 6 FT) complete, per specifications 870 lf					
Unit Price	\$654.140	\$750.00	\$595.000	\$740.00	\$715.000
Extended Price	569,101.80	652,500.00	517,650.00	643,800.00	622,050.00
Line 20 RC PIPE (CL III)(36 IN) installed complete, per specifications 72 lf					
Unit Price	\$174.170	\$217.00	\$80.000	\$131.00	\$216.000
Extended Price	12,540.24	15,624.00	5,760.00	9,432.00	15,552.00

To be awarded by line item	Williams Ditching LLC	Holmes Construction Company	Spiess Construction Co Inc	Ltd	Inc
Line 16 Gabion Mattresses (Galvanized) (12 IN) (TxDOT Item No 459) installed complete, per specifications 111 sy					
Unit Price	\$46.130	\$170.00	\$80.000	\$75.00	\$158.000
Extended Price	5,120.43	18,870.00	8,880.00	8,325.00	17,538.00
Line 17 Gabions (3'x3')(Galvanized), (TxDOT Item No 459) installed complete, per specifications 5 cy					
Unit Price	\$115.000	\$490.00	\$200.000	\$385.00	\$295.000
Extended Price	575.00	2,450.00	1,000.00	1,925.00	1,475.00
Line 18 Conc Box Culv (6FT x 5 FT) complete, per specifications 480 lf					
Unit Price	\$437.870	\$547.00	\$365.000	\$558.30	\$520.000
Extended Price	210,177.60	262,560.00	175,200.00	267,984.00	249,600.00
Line 19 Conc Box Culv (8 FT x 6 FT) complete, per specifications 870 lf					
Unit Price	\$654.140	\$750.00	\$595.000	\$740.00	\$715.000
Extended Price	569,101.80	652,500.00	517,650.00	643,800.00	622,050.00
Line 20 RC PIPE (CL III)(36 IN) installed complete, per specifications 72 lf					
Unit Price	\$174.170	\$217.00	\$80.000	\$131.00	\$216.000
Extended Price	12,540.24	15,624.00	5,760.00	9,432.00	15,552.00

To be awarded by line item Williams Ditching LLC Holmes Construction Company Spiess Construction Co Inc L A Fuller & Sons Construction D E Rice Construction Company Inc

Line 21 RC Pipe (CL III)(42 IN)( TxDOT Item No 464) installed complete, per specifications 72 lf									
Unit Price	\$220.740	\$260.00	\$110.000	\$175.00	\$258.000				
Extended Price	15,893.28	18,720.00	7,920.00	12,600.00	18,576.00				

Line 22 Manhole (complete) (Junction Box) (Type 1) (TxDOT Item 465) installed complete, per specifications 1 ea									
Unit Price	\$10,335.000	\$8,175.00	\$25,000.000	\$13,541.00	\$8,225.000				
Extended Price	10,335.00	8,175.00	25,000.00	13,541.00	8,225.00				

Line 23 Inlet (compl)(PADZ) (FG)(4 FT x 4 FT - 3 FT x 3 FT) complete per specifications 2 ea									
Unit Price	\$5,660.000	\$4,625.00	\$7,500.000	\$4,961.00	\$4,360.000				
Extended Price	11,320.00	9,250.00	15,000.00	9,922.00	8,720.00				

Line 24 Wingwall (SW-0)(HW=14 ft)(Mod)(TxDOT Item No 466) installed complete, per specifications 1 ea									
Unit Price	\$18,240.000	\$32,550.00	\$12,000.000	\$35,387.00	\$28,065.000				
Extended Price	18,240.00	32,550.00	12,000.00	35,387.00	28,065.00				

To be awarded by line item	Williams Ditching LLC	Holmes Construction Company	Spieess Construction Co Inc	Ltd	Inc
Line 11 D-GR HMA (SQ) TY-B PG64-22, (TxDOT Item No 3267) complete per specifications					
34 Ton					
Unit Price	\$104.060	\$302.00	\$100.000	\$443.00	\$220.000
Extended Price	3,538.04	10,268.00	3,400.00	15,062.00	7,480.00
Line 12 D-GR HMA (SQ) Ty-D PG64-22, )TxDOT Item No 3267) complete, per specifications					
17 Ton					
Unit Price	\$270.060	\$300.00	\$100.000	\$670.00	\$440.000
Extended Price	4,591.02	5,100.00	1,700.00	11,390.00	7,480.00
Line 13 Trench Excavation Protection, compele, per specifications					
1,531 LF					
Unit Price	\$12.920	\$9.75	\$1.000	\$27.00	\$10.000
Extended Price	19,780.52	14,927.25	1,531.00	41,337.00	15,310.00
Line 14 RIPRAP (Conc)(4IN) complete, per specifications					
40 CY					
Unit Price	\$226.500	\$495.00	\$500.000	\$612.00	\$105.000
Extended Price	9,060.00	19,800.00	20,000.00	24,480.00	4,200.00
Line 15 RIPRAP (Stone Common (Dry)(18 IN) complete, per specifications					
16 CY					
Unit Price	\$206.940	\$215.00	\$75.000	\$220.00	\$280.000
Extended Price	3,311.04	3,440.00	1,200.00	3,520.00	4,480.00

To be awarded by line item	Williams Ditching LLC	Holmes Construction Company	Spieess Construction Co Inc	L A Fuller & Sons Construction Ltd	D E Rice Construction Company Inc
Line 11 D-GR HMA (SQ) TY-B PG64-22, (TxDOT Item No 3267) complete per specifications					
34 Ton					
Unit Price	\$104.060	\$302.00	\$100.000	\$443.00	\$220.000
Extended Price	3,538.04	10,268.00	3,400.00	15,062.00	7,480.00
Line 12 D-GR HMA (SQ) Ty-D PG64-22, (TxDOT Item No 3267) complete, per specifications					
17 Ton					
Unit Price	\$270.060	\$300.00	\$100.000	\$670.00	\$440.000
Extended Price	4,591.02	5,100.00	1,700.00	11,390.00	7,480.00
Line 13 Trench Excavation Protection, comple, per specifications					
1,531 LF					
Unit Price	\$12.920	\$9.75	\$1.000	\$27.00	\$10.000
Extended Price	19,780.52	14,927.25	1,531.00	41,337.00	15,310.00
Line 14 RIPRAP (Conc)(4IN) complete, per specifications					
40 CY					
Unit Price	\$226.500	\$495.00	\$500.000	\$612.00	\$105.000
Extended Price	9,060.00	19,800.00	20,000.00	24,480.00	4,200.00
Line 15 RIPRAP (Stone Common (Dry))(18 IN) complete, per specifications					
16 CY					
Unit Price	\$206.940	\$215.00	\$75.000	\$220.00	\$280.000
Extended Price	3,311.04	3,440.00	1,200.00	3,520.00	4,480.00

To be awarded by line item	Williams Ditching LLC	Holmes Construction Company	Spieess Construction Co Inc	L A Fuller & Sons Construction Ltd	D E Rice Construction Company Inc
Line 16 Gabion Mattresses (Galvanized) (12 IN) (TxDOT Item No 459) installed complete, per specifications 111 sy					
Unit Price	\$46.130	\$170.00	\$80.000	\$75.00	\$158.000
Extended Price	5,120.43	18,870.00	8,880.00	8,325.00	17,538.00
Line 17 Gabions (3'x3')(Galvanized), (TxDOT Item No 459) installed complete, per specifications 5 cy					
Unit Price	\$115.000	\$490.00	\$200.000	\$385.00	\$295.000
Extended Price	575.00	2,450.00	1,000.00	1,925.00	1,475.00
Line 18 Conc Box Culv (6FT x 5 FT) complete, per specifications 480 lf					
Unit Price	\$437.870	\$547.00	\$365.000	\$558.30	\$520.000
Extended Price	210,177.60	262,560.00	175,200.00	267,984.00	249,600.00
Line 19 Conc Box Culv (8 FT x 6 FT) complete, per specifications 870 lf					
Unit Price	\$654.140	\$750.00	\$595.000	\$740.00	\$715.000
Extended Price	569,101.80	652,500.00	517,650.00	643,800.00	622,050.00
Line 20 RC PIPE (CL III)(36 IN) installed complete, per specifications 72 lf					
Unit Price	\$174.170	\$217.00	\$80.000	\$131.00	\$216.000
Extended Price	12,540.24	15,624.00	5,760.00	9,432.00	15,552.00



To be awarded by line item	Williams Ditching LLC	Holmes Construction Company	Spiess Construction Co Inc	Ltd	Inc
Line 16 Gabion Mattresses (Galvanized) (12 IN) (TxDOT Item No 459) installed complete, per specifications 111 sy					
Unit Price	\$46.130	\$170.00	\$80.000	\$75.00	\$158.000
Extended Price	5,120.43	18,870.00	8,880.00	8,325.00	17,538.00
Line 17 Gabions (3'x3')(Galvanized), (TxDOT Item No 459) installed complete, per specifications 5 cy					
Unit Price	\$115.000	\$490.00	\$200.000	\$385.00	\$295.000
Extended Price	575.00	2,450.00	1,000.00	1,925.00	1,475.00
Line 18 Conc Box Culv (6FT x 5 FT) complete, per specifications 480 lf					
Unit Price	\$437.870	\$547.00	\$365.000	\$558.30	\$520.000
Extended Price	210,177.60	262,560.00	175,200.00	267,984.00	249,600.00
Line 19 Conc Box Culv (8 FT x 6 FT) complete, per specifications 870 lf					
Unit Price	\$654.140	\$750.00	\$595.000	\$740.00	\$715.000
Extended Price	569,101.80	652,500.00	517,650.00	643,800.00	622,050.00
Line 20 RC PIPE (CL III)(36 IN) installed complete, per specifications 72 lf					
Unit Price	\$174.170	\$217.00	\$80.000	\$131.00	\$216.000
Extended Price	12,540.24	15,624.00	5,760.00	9,432.00	15,552.00

To be awarded by line item Williams Ditching LLC Holmes Construction Company Spiess Construction Co Inc L A Fuller & Sons Construction D E Rice Construction Company Inc

Line 21 RC Pipe (CL III)(42 IN)( TxDOT Item No 464) installed complete, per specifications 72 lf									
Unit Price	\$220.740	\$260.00	\$110.000	\$175.00	\$258.000				
Extended Price	15,893.28	18,720.00	7,920.00	12,600.00	18,576.00				

Line 22 Manhole (complete) (Junction Box) (Type 1) (TxDOT Item 465) installed complete, per specifications 1 ea									
Unit Price	\$10,335.000	\$8,175.00	\$25,000.000	\$13,541.00	\$8,225.000				
Extended Price	10,335.00	8,175.00	25,000.00	13,541.00	8,225.00				

Line 23 Inlet (compl)(PADZ) (FG)(4 FT x 4 FT - 3 FT x 3 FT) complete per specifications 2 ea									
Unit Price	\$5,660.000	\$4,625.00	\$7,500.000	\$4,961.00	\$4,360.000				
Extended Price	11,320.00	9,250.00	15,000.00	9,922.00	8,720.00				

Line 24 Wingwall (SW-0)(HW=14 ft)(Mod)(TxDOT Item No 466) installed complete, per specifications 1 ea									
Unit Price	\$18,240.000	\$32,550.00	\$12,000.000	\$35,387.00	\$28,065.000				
Extended Price	18,240.00	32,550.00	12,000.00	35,387.00	28,065.00				

To be awarded by line item	Williams Ditching LLC	Holmes Construction Company	Spieess Construction Co Inc	L A Fuller & Sons Construction Ltd	D E Rice Construction Company Inc
Line 4 Furnish, install and maintain Traffic control Plan, (COA 9.04) complete, per specifications					
1 ls	\$9,623.000	\$36,450.00	\$75,000.000	\$49,000.00	\$10,000.000
Unit Price					
Extended Price	9,623.00	36,450.00	75,000.00	49,000.00	10,000.00
Line 5 Mobilization / Demobilization including Insurance, Payment Bond, Performance Bond, Maintenance Bond and related Ancillary Costs. (Shall not exceed five percent (5%) of the total construction cost(COA 10.01), per specifications					
1 ls	\$104,949.860	\$131,100.00	\$175,000.000	\$128,040.00	\$65,300.000
Unit Price					
Extended Price	104,949.86	131,100.00	175,000.00	128,040.00	65,300.00
Line 6 Remove Stab Base & Asph Pav (8" - 20"), complete, per specifications					
145 sy	\$7.380	\$52.00	\$20.000	\$24.00	\$35.000
Unit Price					
Extended Price	1,070.10	7,540.00	2,900.00	3,480.00	5,075.00

To be awarded by line item	Williams Ditching LLC	Holmes Construction Company	Spiess Construction Co Inc	L A Fuller & Sons Construction	D E Rice Construction Company
Line 7 Furnish, haul, place and compact new fill, select material (Pl<15). Material is to be placed in lifts not to exceed six inches (6") and compacted to 95% Proctor, (TxDOT Item No 132), complete , per specifications					
28 cy					
Unit Price	\$94.290	\$201.00	\$50.000	\$115.00	\$150.000
Extended Price	2,640.12	5,628.00	1,400.00	3,220.00	4,200.00
Line 8 Drill Seed (Perm)(Urban)(Clay), complete, per specifications					
115,000 sy					
Unit Price	\$0.120	\$0.60	\$0.500	\$0.65	\$0.150
Extended Price	13,800.00	69,000.00	57,500.00	74,750.00	17,250.00
Line 9 Sediment control, Soil Retention Blanket, (Flexible Channel Liner) (Class 2 Type F), (TxDOT Item No 169) installed complete per specifications					
31,000 sy					
Unit Price	\$0.770	\$0.76	\$0.500	\$1.20	\$2.000
Extended Price	23,870.00	23,560.00	15,500.00	37,200.00	62,000.00
Line 10 FL BS (CMP in PLC)(TY A or B)(GR 4)(12") complete, per specifications					
145 sy					
Unit Price	\$31.760	\$83.45	\$15.000	\$38.00	\$66.000
Extended Price	4,605.20	12,100.25	2,175.00	5,510.00	9,570.00

To be awarded by line item	Williams Ditching LLC	Holmes Construction Company	Spieess Construction Co Inc	L A Fuller & Sons Construction Ltd	D E Rice Construction Company Inc
Line 11 D-GR HMA (SQ) TY-B PG64-22, (TxDOT Item No 3267) complete per specifications					
34 Ton					
Unit Price	\$104.060	\$302.00	\$100.000	\$443.00	\$220.000
Extended Price	3,538.04	10,268.00	3,400.00	15,062.00	7,480.00
Line 12 D-GR HMA (SQ) Ty-D PG64-22, (TxDOT Item No 3267) complete, per specifications					
17 Ton					
Unit Price	\$270.060	\$300.00	\$100.000	\$670.00	\$440.000
Extended Price	4,591.02	5,100.00	1,700.00	11,390.00	7,480.00
Line 13 Trench Excavation Protection, comple, per specifications					
1,531 LF					
Unit Price	\$12.920	\$9.75	\$1.000	\$27.00	\$10.000
Extended Price	19,780.52	14,927.25	1,531.00	41,337.00	15,310.00
Line 14 RIPRAP (Conc)(4IN) complete, per specifications					
40 CY					
Unit Price	\$226.500	\$495.00	\$500.000	\$612.00	\$105.000
Extended Price	9,060.00	19,800.00	20,000.00	24,480.00	4,200.00
Line 15 RIPRAP (Stone Common (Dry)(18 IN) complete, per specifications					
16 CY					
Unit Price	\$206.940	\$215.00	\$75.000	\$220.00	\$280.000
Extended Price	3,311.04	3,440.00	1,200.00	3,520.00	4,480.00

To be awarded by line item	Williams Ditching LLC	Holmes Construction Company	Spieess Construction Co Inc	Ltd	Inc
Line 11 D-GR HMA (SQ) TY-B PG64-22, (TxDOT Item No 3267) complete per specifications					
34 Ton					
Unit Price	\$104.060	\$302.00	\$100.000	\$443.00	\$220.000
Extended Price	3,538.04	10,268.00	3,400.00	15,062.00	7,480.00
Line 12 D-GR HMA (SQ) Ty-D PG64-22, )TxDOT Item No 3267) complete, per specifications					
17 Ton					
Unit Price	\$270.060	\$300.00	\$100.000	\$670.00	\$440.000
Extended Price	4,591.02	5,100.00	1,700.00	11,390.00	7,480.00
Line 13 Trench Excavation Protection, compele, per specifications					
1,531 LF					
Unit Price	\$12.920	\$9.75	\$1.000	\$27.00	\$10.000
Extended Price	19,780.52	14,927.25	1,531.00	41,337.00	15,310.00
Line 14 RIPRAP (Conc)(4IN) complete, per specifications					
40 CY					
Unit Price	\$226.500	\$495.00	\$500.000	\$612.00	\$105.000
Extended Price	9,060.00	19,800.00	20,000.00	24,480.00	4,200.00
Line 15 RIPRAP (Stone Common (Dry)(18 IN) complete, per specifications					
16 CY					
Unit Price	\$206.940	\$215.00	\$75.000	\$220.00	\$280.000
Extended Price	3,311.04	3,440.00	1,200.00	3,520.00	4,480.00

To be awarded by line item	Williams Ditching LLC	Holmes Construction Company	Spiess Construction Co Inc	Ltd	Inc
Line 16 Gabion Mattresses (Galvanized) (12 IN) (TxDOT Item No 459) installed complete, per specifications 111 sy					
Unit Price	\$46.130	\$170.00	\$80.000	\$75.00	\$158.000
Extended Price	5,120.43	18,870.00	8,880.00	8,325.00	17,538.00
Line 17 Gabions (3'x3')(Galvanized), (TxDOT Item No 459) installed complete, per specifications 5 cy					
Unit Price	\$115.000	\$490.00	\$200.000	\$385.00	\$295.000
Extended Price	575.00	2,450.00	1,000.00	1,925.00	1,475.00
Line 18 Conc Box Culv (6FT x 5 FT) complete, per specifications 480 lf					
Unit Price	\$437.870	\$547.00	\$365.000	\$558.30	\$520.000
Extended Price	210,177.60	262,560.00	175,200.00	267,984.00	249,600.00
Line 19 Conc Box Culv (8 FT x 6 FT) complete, per specifications 870 lf					
Unit Price	\$654.140	\$750.00	\$595.000	\$740.00	\$715.000
Extended Price	569,101.80	652,500.00	517,650.00	643,800.00	622,050.00
Line 20 RC PIPE (CL III)(36 IN) installed complete, per specifications 72 lf					
Unit Price	\$174.170	\$217.00	\$80.000	\$131.00	\$216.000
Extended Price	12,540.24	15,624.00	5,760.00	9,432.00	15,552.00

To be awarded by line item	Williams Ditching LLC	Holmes Construction Company	Spieess Construction Co Inc	L A Fuller & Sons Construction Ltd	D E Rice Construction Company Inc
Line 4 Furnish, install and maintain Traffic control Plan, (COA 9.04) complete, per specifications					
1 ls	\$9,623.000	\$36,450.00	\$75,000.000	\$49,000.00	\$10,000.000
Unit Price					
Extended Price	9,623.00	36,450.00	75,000.00	49,000.00	10,000.00
Line 5 Mobilization / Demobilization including Insurance, Payment Bond, Performance Bond, Maintenance Bond and related Ancillary Costs. (Shall not exceed five percent (5%) of the total construction cost(COA 10.01), per specifications					
1 ls	\$104,949.860	\$131,100.00	\$175,000.000	\$128,040.00	\$65,300.000
Unit Price					
Extended Price	104,949.86	131,100.00	175,000.00	128,040.00	65,300.00
Line 6 Remove Stab Base & Asph Pav (8" - 20"), complete, per specifications					
145 sy	\$7.380	\$52.00	\$20.000	\$24.00	\$35.000
Unit Price					
Extended Price	1,070.10	7,540.00	2,900.00	3,480.00	5,075.00



To be awarded by line item	Williams Ditching LLC	Holmes Construction Company	Spiess Construction Co Inc	L A Fuller & Sons Construction	D E Rice Construction Company
Line 7 Furnish, haul, place and compact new fill, select material (Pl<15). Material is to be placed in lifts not to exceed six inches (6") and compacted to 95% Proctor, (TxDOT Item No 132), complete , per specifications					
28 cy					
Unit Price	\$94.290	\$201.00	\$50.000	\$115.00	\$150.000
Extended Price	2,640.12	5,628.00	1,400.00	3,220.00	4,200.00
Line 8 Drill Seed (Perm)(Urban)(Clay), complete, per specifications					
115,000 sy					
Unit Price	\$0.120	\$0.60	\$0.500	\$0.65	\$0.150
Extended Price	13,800.00	69,000.00	57,500.00	74,750.00	17,250.00
Line 9 Sediment control, Soil Retention Blanket, (Flexible Channel Liner) (Class 2 Type F), (TxDOT Item No 169) installed complete per specifications					
31,000 sy					
Unit Price	\$0.770	\$0.76	\$0.500	\$1.20	\$2.000
Extended Price	23,870.00	23,560.00	15,500.00	37,200.00	62,000.00
Line 10 FL BS (CMP in PLC)(TY A or B)(GR 4)(12") complete, per specifications					
145 sy					
Unit Price	\$31.760	\$83.45	\$15.000	\$38.00	\$66.000
Extended Price	4,605.20	12,100.25	2,175.00	5,510.00	9,570.00

To be awarded by line item	Williams Ditching LLC	Holmes Construction Company	Spieess Construction Co Inc	Ltd	Inc
Line 11 D-GR HMA (SQ) TY-B PG64-22, (TxDOT Item No 3267) complete per specifications					
34 Ton					
Unit Price	\$104.060	\$302.00	\$100.000	\$443.00	\$220.000
Extended Price	3,538.04	10,268.00	3,400.00	15,062.00	7,480.00
Line 12 D-GR HMA (SQ) Ty-D PG64-22, )TxDOT Item No 3267) complete, per specifications					
17 Ton					
Unit Price	\$270.060	\$300.00	\$100.000	\$670.00	\$440.000
Extended Price	4,591.02	5,100.00	1,700.00	11,390.00	7,480.00
Line 13 Trench Excavation Protection, compele, per specifications					
1,531 LF					
Unit Price	\$12.920	\$9.75	\$1.000	\$27.00	\$10.000
Extended Price	19,780.52	14,927.25	1,531.00	41,337.00	15,310.00
Line 14 RIPRAP (Conc)(4IN) complete, per specifications					
40 CY					
Unit Price	\$226.500	\$495.00	\$500.000	\$612.00	\$105.000
Extended Price	9,060.00	19,800.00	20,000.00	24,480.00	4,200.00
Line 15 RIPRAP (Stone Common (Dry)(18 IN) complete, per specifications					
16 CY					
Unit Price	\$206.940	\$215.00	\$75.000	\$220.00	\$280.000
Extended Price	3,311.04	3,440.00	1,200.00	3,520.00	4,480.00

To be awarded by line item	Williams Ditching LLC	Holmes Construction Company	Spieess Construction Co Inc	Ltd	Inc
Line 11 D-GR HMA (SQ) TY-B PG64-22, (TxDOT Item No 3267) complete per specifications					
34 Ton					
Unit Price	\$104.060	\$302.00	\$100.000	\$443.00	\$220.000
Extended Price	3,538.04	10,268.00	3,400.00	15,062.00	7,480.00
Line 12 D-GR HMA (SQ) Ty-D PG64-22, )TxDOT Item No 3267) complete, per specifications					
17 Ton					
Unit Price	\$270.060	\$300.00	\$100.000	\$670.00	\$440.000
Extended Price	4,591.02	5,100.00	1,700.00	11,390.00	7,480.00
Line 13 Trench Excavation Protection, compele, per specifications					
1,531 LF					
Unit Price	\$12.920	\$9.75	\$1.000	\$27.00	\$10.000
Extended Price	19,780.52	14,927.25	1,531.00	41,337.00	15,310.00
Line 14 RIPRAP (Conc)(4IN) complete, per specifications					
40 CY					
Unit Price	\$226.500	\$495.00	\$500.000	\$612.00	\$105.000
Extended Price	9,060.00	19,800.00	20,000.00	24,480.00	4,200.00
Line 15 RIPRAP (Stone Common (Dry)(18 IN) complete, per specifications					
16 CY					
Unit Price	\$206.940	\$215.00	\$75.000	\$220.00	\$280.000
Extended Price	3,311.04	3,440.00	1,200.00	3,520.00	4,480.00

Line 16 Gabion Mattresses (Galvanized) (12 IN) (TxDOT Item No 459) installed complete, per specifications 111 sy									
Unit Price	\$46.130	\$170.00	\$80.000	\$75.00	8,325.00	\$158.000			
Extended Price	5,120.43	18,870.00	8,880.00	8,880.00					17,538.00

Line 17 Gabions (3'x3')(Galvanized), (TxDOT Item No 459) installed complete, per specifications 5 cy									
Unit Price	\$115.000	\$490.00	\$200.000	\$385.00	1,925.00	\$295.000			
Extended Price	575.00	2,450.00	1,000.00	1,000.00					1,475.00

Line 18 Conc Box Culv (6FT x 5 FT) complete, per specifications 480 lf									
Unit Price	\$437.870	\$547.00	\$365.000	\$558.30	267,984.00	\$520.000			
Extended Price	210,177.60	262,560.00	175,200.00	267,984.00					249,600.00

Line 19 Conc Box Culv (8 FT x 6 FT) complete, per specifications 870 lf									
Unit Price	\$654.140	\$750.00	\$595.000	\$740.00	643,800.00	\$715.000			
Extended Price	569,101.80	652,500.00	517,650.00	643,800.00					622,050.00

Line 20 RC PIPE (CL III)(36 IN) installed complete, per specifications 72 lf									
Unit Price	\$174.170	\$217.00	\$80.000	\$131.00	9,432.00	\$216.000			
Extended Price	12,540.24	15,624.00	5,760.00	9,432.00					15,552.00



Line 25 Remove Structure (Set) complete, per specifications 2 ea	Unit Price \$1,819.500	\$7,300.00	14,600.00	\$1,000.000	2,000.00	\$498.00	996.00	\$6,965.000	13,930.00
	Extended Price	3,639.00							

Line 26 Remove Structure (Pipe) complete, per specifications 90 lf	Unit Price \$36.900	\$14.00	1,260.00	\$30.000	2,700.00	\$7.50	675.00	\$10.000	900.00
	Extended Price	3,321.00							

Line 27 Construction exits (Install) (TY 1) complete, per specifications 156 sy	Unit Price \$15.810	\$55.00	8,580.00	\$40.000	6,240.00	\$23.00	3,588.00	\$22.500	3,510.00
	Extended Price	2,466.36							

Line 28 Wire Fence (TV C) complete, per specifications 900 lf	Unit Price \$11.500	\$8.50	7,650.00	\$25.000	22,500.00	\$9.50	8,550.00	\$8.000	7,200.00
	Extended Price	10,350.00							

Line 29 Initial Dewatering, complete, per specifications 1 ls	Unit Price \$43,270.000	\$71,000.00	71,000.00	\$225,000.000	225,000.00	\$501,100.00	501,100.00	\$67,210.000	67,210.00
	Extended Price	43,270.00							

To be awarded by line item	Williams Ditching LLC	Holmes Construction Company	Spiess Construction Co Inc	L A Fuller & Sons Construction Ltd	D E Rice Construction Company Inc
Line 30 Additional Pumping, complete, per specifications 20 days					
Unit Price	\$2,046.870	\$3,250.00	\$1,000.000	\$2,950.00	\$1,500.000
Extended Price	40,937.40	65,000.00	20,000.00	59,000.00	30,000.00
Line 31 Additional Pumping Mobilization / Demobilization, complete, per specifications 2 ea					
Unit Price	\$14,060.000	\$26,250.00	\$30,000.000	\$8,200.00	\$25,894.000
Extended Price	28,120.00	52,500.00	60,000.00	16,400.00	51,788.00
Line 32 Alternate Bid - Concrete RIPRAP (6") complete, per specifications 2,400 sy					
Unit Price	\$28.650	\$58.50	\$50.000	\$76.80	\$315,000.000
Extended Price	68,760.00	140,400.00	120,000.00	184,320.00	756,000,000.00
Bid Total	2,418,171.41	3,420,792.50	4,152,156.00	4,268,734.00	759,446,684.00
Award to Vendor	2,418,171.41				



# Amarillo City Council Agenda Transmittal Memo



<b>Meeting Date</b>	June 27, 2017	<b>Council Priority</b>	Downtown Redevelopment Best Practices
---------------------	---------------	-------------------------	--

<b>Department</b>	Legal
-------------------	-------

**Agenda Caption**

Discuss and consider action to approve and extend Engagement of Winstead PC to assist in negotiation of long term lease agreement and related matters with affiliated Minor League Baseball team.

**Agenda Item Summary**

On December 21, 2016, the Sports Venue Group of the Houston office of Winstead PC was engaged by the City Attorney to consult with the City Manager, City Attorney and City Staff on matters related to negotiations of a long term lease agreement with representatives of affiliated Minor League Baseball teams. The current Engagement is limited by time and total cost of \$50,000. As negotiations now reach critical final stages, continuation of the Engagement with elimination of the limit on total costs (if necessary) is recommended.

**Requested Action**

Approve the Engagement of Winstead PC to assist in negotiations of a long term lease with an affiliated Minor League Baseball team as tenant for the MPEV.

**Funding Summary**

Legal expenses are part of administrative costs for development of the MPEV

**Community Engagement Summary**

N/A

**City Manager Recommendation**

The City Manager, City Attorney and Staff recommend approval.





4

# Amarillo City Council Agenda Transmittal Memo



<b>Meeting Date</b>	6/27/2017	<b>Council Priority</b>	Infrastructure Initiative
---------------------	-----------	-------------------------	---------------------------

<b>Department</b>	Capital Projects & Development Engineering
-------------------	--

## Agenda Caption

Award – BID # 5761 JOB # 430036 Landfill Gas Collection and Control System – Phase I  
Landmarc Environmental Systems, LLC - \$3,993,577.00

## Agenda Item Summary

This item is to approve the contract for Solid Waste Improvements for the construction of a landfill gas collection and control system at the City of Amarillo landfill.

## Requested Action

Consider approval and award to Landmarc Environmental Systems, LLC - \$3,993,577.00

## Funding Summary

Funding for this project is available in the Project Budget Number 430036.17400.1040

## Community Engagement Summary

This project will have minimal negative impact on the community.

## Staff Recommendation

City Staff is recommending approval and award of the contract.

Bid No. 5761 Landfill Gas Collection and Control Systems - Phase 1  
 Opened 4:00 p.m., May 25, 2017

To be awarded as one lot	Landmarc Environmental Systems LLC	TriCon Works LLC	SCS Field Services	Spiess construction Co Inc
Line 1 Performance and Payment Bonds and Insurance (Maximum 1% of 1 LS Unit Price Extended Price	\$39,500.00 39,500.00	\$39,142.00 39,142.00	\$44,000.000 44,000.00	\$55,000.00 55,000.00
Line 2 Mobilization, per specifications 1 LS Unit Price Extended Price	\$45,575.00 45,575.00	\$195,000.00 195,000.00	\$210,000.00 210,000.00	\$300,000.00 300,000.00
Line 3 Contractor Health and Safety Plan, per specifications 1 LS Unit Price Extended Price	\$1,250.00 1,250.00	\$10,000.00 10,000.00	\$500.00 500.00	\$45,000.00 45,000.00
Line 4 Erosion and Sediment Control, per specifications 1 LS Unit Price Extended Price	\$36,000.00 36,000.00	\$20,000.00 20,000.00	\$11,000.00 11,000.00	\$30,000.00 30,000.00

To be awarded as one lot	Landmarc Environmental Systems LLC	TriCon Works LLC	SCS Field Services	Spiess construction Co Inc
Line 5 Site Survey and Controls, per specifications 1 LS				
Unit Price	\$51,750.00	\$58,750.00	\$90,000.00	\$150,000.00
Extended Price	51,750.00	58,750.00	90,000.00	150,000.00
Line 6 Vertical Gas Extraction Well Installation, per specifications 4,047 VF				
Unit Price	\$55.00	\$70.00	\$89.00	\$90.00
Extended Price	222,585.00	283,290.00	360,183.00	364,230.00
Line 7 Vertical Caisson Well Installation, per specifications 948 VF				
Unit Price	\$102.250	\$110.00	\$118.00	\$132.00
Extended Price	96,933.00	104,280.00	111,864.00	125,136.00
Line 8 Vertical Remote Caisson Well Installation, per specifications 243 VF				
Unit Price	\$117.750	\$115.00	\$130.00	\$150.00
Extended Price	28,613.25	27,945.00	31,590.00	36,450.00
Line 9 Horizontal Gas Extraction Well Installation per specifications 7,536 LF				
Unit Price	\$44.000	\$58.00	\$62.000	\$70.00
Extended Price	331,584.00	437,088.00	467,232.00	527,520.00

To be awarded as one lot	Landmarc Environmental Systems LLC	TriCon Works LLC	SCS Field Services	Spieess construction Co Inc
Line 10 Vertical Component of Horizontal Wells , per specifications 90 VF				
Unit Price	\$30.000	\$70.00	\$500.000	\$50.00
Extended Price	2,700.00	6,300.00	45,000.00	4,500.00
Line 11 LLDPE Liner for Horizontal Wells, per specifications 3,333 SY				
Unit Price	\$5.000	\$5.00	\$4.000	\$17.00
Extended Price	16,665.00	16,665.00	13,332.00	56,661.00
Line 12 Vertical Well Head Installation , per specifications 87 EA				
Unit Price	\$950.000	\$950.00	\$950.000	\$500.00
Extended Price	82,650.00	82,650.00	82,650.00	43,500.00
Line 13 Horizontal Wellhead Installation , per specifications 16 EA				
Unit Price	\$1,050.000	\$950.00	\$950.000	\$500.00
Extended Price	16,800.00	15,200.00	15,200.00	8,000.00
Line14 HDPE Lateral Piping (6"), per specifications 23,495 LF				
Unit Price	\$18.500	\$19.00	\$26.500	\$50.00
Extended Price	434,657.50	446,405.00	622,617.50	1,174,750.00

To be awarded as one lot	Landmarc Environmental Systems LLC	TriCon Works LLC	SCS Field Services	Spieess construction Co Inc
Line 15 HDPE Sub-Header Piping (12"), per specifications 8,679 LF				
Unit Price	\$35.500	\$35.00	\$46.000	\$62.00
Extended Price	308,104.50	303,765.00	399,234.00	538,098.00
Line 16 HDPE Header Piping (18") , per specifications 14,676 LF				
Unit Price	\$56.250	\$47.00	\$82.000	\$80.00
Extended Price	825,525.00	689,772.00	1,203,432.00	1,174,080.00
Line 17 HDPE Airline Piping (2")(Common Trench), per 13,963 LF				
Unit Price	\$2.750	\$2.00	\$2.000	\$4.00
Extended Price	38,398.25	27,926.00	27,926.00	55,852.00
Line 18 HDPE Forcemain Piping (4")(Common Trench), per 6,306 LF				
Unit Price	\$5.000	\$4.00	\$5.000	\$12.00
Extended Price	31,530.00	25,224.00	31,530.00	75,672.00
Line 19 Dual Contained HDPE Forcemain Piping (4"x8")(Common 7,657 LF				
Unit Price	\$17.750	\$16.00	\$19.000	\$22.00
Extended Price	135,911.75	122,512.00	145,483.00	168,454.00

To be awarded as one lot	Landmarc Environmental Systems LLC	TriCon Works LLC	SCS Field Services	Spiess construction Co Inc
Line 20 Dual Contained Condensate Sumps (including pneumatic pumps 8 EA				
Unit Price	\$33,250.000	\$31,500.00	\$37,000.000	\$40,000.00
Extended Price	266,000.00	252,000.00	296,000.00	320,000.00
Line 21 Addition for Trench Depth 4'-8', per specifications 18,792 LF				
Unit Price	\$5.250	\$3.50	\$12.000	\$10.00
Extended Price	98,658.00	65,772.00	225,504.00	187,920.00
Line 22 Addition for Trench Depth 8'- 12', per specifications 1,856 LF				
Unit Price	\$8.500	\$11.00	\$15.000	\$15.00
Extended Price	15,776.00	20,416.00	27,840.00	27,840.00
Line 23 Addition for Trench Depth Greater than 12', per specifications 597 LF				
Unit Price	\$14.750	\$20.00	\$23.000	\$20.00
Extended Price	8,805.75	11,940.00	13,731.00	11,940.00
Line 24 Crossing for Low Lying Area, per specifications 8 EA				
Unit Price	\$1,585.000	\$5,200.00	\$4,800.000	\$1,000.00
Extended Price	12,680.00	41,600.00	38,400.00	8,000.00

To be awarded as one lot	Landmarc Environmental Systems LLC	TriCon Works LLC	SCS Field Services	Spieess construction Co Inc
Line 25 Armored Road Crossing , per specifications 13 EA				
Unit Price	\$2,275.000	\$2,500.00	\$5,000.000	\$1,000.00
Extended Price	29,575.00	32,500.00	65,000.00	13,000.00
Line 26 18" Header Access Point, per specifications 5 EA				
Unit Price	\$5,450.000	\$3,400.00	\$7,500.000	\$5,000.00
Extended Price	27,250.00	17,000.00	37,500.00	25,000.00
Line 27 12" Sub-Header Access Point, per specifications 5 EA				
Unit Price	\$1,290.000	\$3,000.00	\$5,500.000	\$1,200.00
Extended Price	6,450.00	15,000.00	27,500.00	6,000.00
Line 28 18" Valve and Vault, per specifications 7 EA				
Unit Price	\$21,900.000	\$10,200.00	\$17,000.000	\$18,000.00
Extended Price	153,300.00	71,400.00	119,000.00	126,000.00
Line 29 12" Valve and Vault, per specifications 5 EA				
Unit Price	\$11,200.000	\$4,490.00	\$8,500.000	\$11,000.00
Extended Price	56,000.00	22,450.00	42,500.00	55,000.00

To be awarded as one lot	Landmarc Environmental Systems LLC	TriCon Works LLC	SCS Field Services	Spiess construction Co Inc
Line 30 4" Forcemain Valve and Vault, per specifications 6 EA				
Unit Price	\$8,500.000	\$1,950.00	\$6,300.000	\$10,000.00
Extended Price	51,000.00	11,700.00	37,800.00	60,000.00
Line 31 2" Airline Valve and Vault , per specifications 6 EA				
Unit Price	\$5,600.000	\$1,350.00	\$5,000.000	\$8,000.00
Extended Price	33,600.00	8,100.00	30,000.00	48,000.00
Line 32 18" Blind Flange, per specifications 1 EA				
Unit Price	\$1,650.000	\$1,305.00	\$2,000.000	\$1,000.00
Extended Price	1,650.00	1,305.00	2,000.00	1,000.00
Line 33 Blower/Flare Station (including all above-ground attributes and air 1 LS				
Unit Price	\$380,000.000	\$425,000.00	\$415,264.000	\$400,000.00
Extended Price	380,000.00	425,000.00	415,264.00	400,000.00
Line 34 Blower/Flare Station Grading, Concrete and Fencing , per 1 LS				
Unit Price	\$31,600.000	\$35,000.00	\$59,000.000	\$165,000.00
Extended Price	31,600.00	35,000.00	59,000.00	165,000.00



To be awarded as one lot	Landmarc Environmental Systems LLC	TriCon Works LLC	SCS Field Services	Spiess construction Co Inc
Line 35 13,700 Gallon Condensate Storage Tank, per specifications				
1 LS				
Unit Price	\$74,500.00	\$69,300.00	\$89,000.00	\$60,000.00
Extended Price	74,500.00	69,300.00	89,000.00	60,000.00
Bid Total	3,993,577.00	4,012,397.00	5,438,812.50	6,447,603.00

Awarded to Vendor 3,993,577.00



# Amarillo City Council Agenda Transmittal Memo



<b>Meeting Date</b>	06/27/2017	<b>Council Priority</b>	Infrastructure
---------------------	------------	-------------------------	----------------

<b>Department</b>	Aviation
-------------------	----------

### Agenda Caption

Approval of State of Texas, Department of Transportation RAMP Grant Application, TxDOT CSJ No.: 42M1704AMRI, Rick Husband Amarillo International Airport.

### Agenda Item Summary

Approval of Routine Airport Maintenance Program (RAMP) Grant Application from TxDOT. This Grant matches funds up to \$50,000 for the general approved maintenance at non-hub primary airports.

### Requested Action

Approve State of Texas, Department of Transportation RAMP Grant, TxDOT CSJ No.: 42M1704AMRI

### Funding Summary

Current projects have been identified and budgeted through FY16/17 budget. Project includes the purchase of 2 Foreign Object Debris (FOD) BOSS Systems, the replacement of 18 individual airfield sign panels, and glass bead stock intended for airfield painting.

### Community Engagement Summary

N/A.

### Staff Recommendation

Staff recommends the approval of TxDOT CSJ No.: 42M1704AMRI



10801 Airport Boulevard  
Tel: (806) 335-1671

Amarillo, TX 79111-1211  
Fax (806) 335-1672

To: Jared Miller  
City Manager

Through: Bob Cowell  
Deputy City Manager

  
4/17/17

From: Mike Conner, C.M.   
Director of Aviation

Date: June 16, 2017

Re: State of Texas, Department of Transportation  
RAMP Grant, TxDOT CSJ No.: 42M1704AMRI

The Airport is in receipt of a grant application from Texas Department of Transportation. The Airport is eligible for the grant due to its classification of a non-hub primary airport. The scope of the grant is to aid airports in funding needed operation/maintenance tasks throughout the year.

Three items have been identified for these grant funds. The first item is the purchase of two tow behind sweeping systems designed to remove Foreign Object Debris (FOD) from the Airport's paved surfaces. The second item is the purchase of 18 new taxiway sign panels identified as needing replacement on the airfield. The third is the purchase of FAA approved glass beads to be used as a reflective component when painting airfield markings. These purchases support the Airport's ongoing preventative maintenance program and overall safety initiative.

The grant will pay for 50% of approved services up to \$50,000. Initial estimates show that the airport will request approximately \$26,000 from TxDOT.

Your consideration of this request is appreciated. Please see the following attachments.

Attachments: TxDOT Grant Application and Council Agenda Transmittal Memo

**TEXAS DEPARTMENT OF TRANSPORTATION  
GRANT FOR ROUTINE AIRPORT MAINTENANCE PROGRAM**

**(State Assisted Airport Routine Maintenance)**

**TxDOT Project ID: M1704AMRI**

**Part I - Identification of the Project**

TO: The City of Amarillo, Texas

FROM: The State of Texas, acting through the Texas Department of Transportation

This Grant is made between the Texas Department of Transportation, (hereinafter referred to as the "State"), on behalf of the State of Texas, and the City of Amarillo, Texas, (hereinafter referred to as the "Sponsor").

This Grant Agreement is entered into between the State and Sponsor shown above, under the authority granted and in compliance with the provisions of the Transportation Code Chapter 21.

The project is for **airport maintenance** at the Rick Husband Amarillo International Airport.

**Part II - Offer of Financial Assistance**

1. For the purposes of this Grant, the annual routine maintenance project cost, Amount A, is estimated as found on Attachment A, Scope of Services, attached hereto and made a part of this grant agreement.

State financial assistance granted will be used solely and exclusively for airport maintenance and other incidental items as approved by the State. Actual work to be performed under this agreement is found on Attachment A, Scope of Services. State financial assistance, Amount B, will be for fifty percent (50%) of the eligible project costs for this project or \$50,000.00, whichever is less, per fiscal year and subject to availability of state appropriations.

Scope of Services, Attachment A, of this Grant, may be amended, subject to availability of state funds, to include additional approved airport maintenance work. Scope amendments require submittal of an Amended Scope of Services, Attachment A.

Services will not be accomplished by the State until receipt of Sponsor's share of project costs.

**Only work items as described in Attachment A, Scope of Services of this Grant are reimbursable under this grant.**

Work shall be accomplished by August 31, 2017, unless otherwise approved by the State.

2. The State shall determine fair and eligible project costs for work scope. Sponsor's share of estimated project costs, Amount C, shall be as found on Attachment A and any amendments.

It is mutually understood and agreed that if, during the term of this agreement, the State determines that there is an overrun in the estimated annual routine maintenance costs, the State may increase the grant to cover the amount of the overrun within the above stated percentages and subject to the maximum amount of state funding.

The State will not authorize expenditures in excess of the dollar amounts identified in this Agreement and any amendments, without the consent of the Sponsor.

3. Sponsor, by accepting this Grant certifies and, upon request, shall furnish proof to the State that it has sufficient funds to meet its share of the costs. The Sponsor grants to the State the right to audit any books and records of the Sponsor to verify expended funds.

Upon execution of this Agreement and written demand by the State, the Sponsor's financial obligation (Amount C) shall be due in cash and payable in full to the State. State may request the Sponsor's financial obligation in partial payments. Should the Sponsor fail to pay their obligation, either in whole or in part, within 30 days of written demand, the State may exercise its rights under Paragraph V-3. Likewise, should the State be unwilling or unable to pay its obligation in a timely manner, the failure to pay shall be considered a breach and the Sponsor may exercise any rights and remedies it has at law or equity.

The State shall reimburse or credit the Sponsor, at the financial closure of the project, any excess funds provided by the Sponsor which exceed Sponsor's share (Amount C).

4. The Sponsor specifically agrees that it shall pay any project costs which exceed the amount of financial participation agreed to by the State. It is further agreed that the Sponsor will reimburse the State for any payment or payments made by the State which are in excess of the percentage of financial assistance (Amount B) as stated in Paragraph II-1.
5. Scope of Services may be accomplished by State contracts or through local contracts of the Sponsor as determined appropriate by the State. All locally contracted work must be approved by the State for scope and reasonable cost. Reimbursement requests for locally contracted work shall be submitted on forms provided by the State and shall include copies of the invoices for materials or services. Payment shall be made for no more than 50% of allowable charges.

The State will not participate in funding for force account work conducted by the Sponsor.

6. This Grant shall terminate upon completion of the scope of services.

### **Part III - Sponsor Responsibilities**

1. In accepting this Grant, if applicable, the Sponsor guarantees that:
  - a. it will, in the operation of the facility, comply with all applicable state and federal laws, rules, regulations, procedures, covenants and assurances required by the State in connection with this Grant; and
  - b. the Airport or navigational facility which is the subject of this Grant shall be controlled by the Sponsor for a period of at least 20 years; and
  - c. consistent with safety and security requirements, it shall make the airport or air navigational facility available to all types, kinds and classes of aeronautical use without discrimination between such types, kinds and classes and shall provide adequate public access during the period of this Grant; and
  - d. it shall not grant or permit anyone to exercise an exclusive right for the conduct of aeronautical activity on or about an airport landing area. Aeronautical activities include, but are not limited to scheduled airline flights, charter flights, flight instruction, aircraft sales, rental and repair, sale of aviation petroleum products and aerial applications. The landing area consists of runways or landing strips, taxiways, parking aprons, roads, airport lighting and navigational aids; and
  - e. it shall not enter into any agreement nor permit any aircraft to gain direct ground access to the sponsor's airport from private property adjacent to or in the immediate area of the airport. Further, Sponsor shall not allow aircraft direct ground access to private property. Sponsor shall be subject to this prohibition, commonly known as a "through-the-fence operation," unless an exception is granted in writing by the State due to extreme circumstances; and
  - f. it shall not permit non-aeronautical use of airport facilities without prior approval of the State; and
  - g. the Sponsor shall submit to the State annual statements of airport revenues and expenses when requested; and
  - h. all fees collected for the use of the airport shall be reasonable and nondiscriminatory. The proceeds from such fees shall be used solely for the development, operation and maintenance of the airport or navigational facility; and

- i. an Airport Fund shall be established by resolution, order or ordinance in the treasury of the Sponsor, or evidence of the prior creation of an existing airport fund or a properly executed copy of the resolution, order, or ordinance creating such a fund, shall be submitted to the State. The fund may be an account as part of another fund, but must be accounted for in such a manner that all revenues, expenses, retained earnings, and balances in the account are discernible from other types of moneys identified in the fund as a whole. All fees, charges, rents, and money from any source derived from airport operations must be deposited in the Airport Fund and shall not be diverted to the general revenue fund or any other revenue fund of the Sponsor. All expenditures from the Airport Fund shall be solely for airport purposes. Sponsor shall be ineligible for a subsequent grant or loan by the State unless, prior to such subsequent approval of a grant or loan, Sponsor has complied with the requirements of this subparagraph; and
  - j. the Sponsor shall operate runway lighting at least at low intensity from sunset to sunrise; and
  - k. insofar as it is reasonable and within its power, Sponsor shall adopt and enforce zoning regulations to restrict the height of structures and use of land adjacent to or in the immediate vicinity of the airport to heights and activities compatible with normal airport operations as provided in Tex. Loc. Govt. Code Ann. Sections 241.001 et seq. (Vernon and Vernon Supp.). Sponsor shall also acquire and retain aviation easements or other property interests in or rights to use of land or airspace, unless sponsor can show that acquisition and retention of such interest will be impractical or will result in undue hardship to Sponsor. Sponsor shall be ineligible for a subsequent grant or loan by the State unless Sponsor has, prior to subsequent approval of a grant or loan, adopted and passed an airport hazard zoning ordinance or order approved by the State.
  - l. mowing services will not be eligible for state financial assistance. Sponsor will be responsible for 100% of any mowing services.
2. The Sponsor, to the extent of its legal authority to do so, shall save harmless the State, the State's agents, employees or contractors from all claims and liability due to activities of the Sponsor, the Sponsor's agents or employees performed under this agreement. The Sponsor, to the extent of its legal authority to do so, shall also save harmless the State, the State's agents, employees or contractors from any and all expenses, including attorney fees which might be incurred by the State in litigation or otherwise resisting claim or liabilities which might be imposed on the State as the result of those activities by the Sponsor, the Sponsor's agents or employees.
3. The Sponsor's acceptance of this Offer and ratification and adoption of this Grant shall be evidenced by execution of this Grant by the Sponsor. The Grant shall comprise a contract, constituting the obligations and rights of the State of Texas and the Sponsor with respect to the accomplishment of the project and the operation and maintenance of the airport.

If it becomes unreasonable or impractical to complete the project, the State may void this agreement and release the Sponsor from any further obligation of project costs.

4. Upon entering into this Grant, Sponsor agrees to name an individual, as the Sponsor's Authorized Representative, who shall be the State's contact with regard to this project. The Representative shall receive all correspondence and documents associated with this grant and shall make or shall acquire approvals and disapprovals for this grant as required on behalf of the Sponsor, and coordinate schedule for work items as required.
5. By the acceptance of grant funds for the maintenance of eligible airport buildings, the Sponsor certifies that the buildings are owned by the Sponsor. The buildings may be leased but if the lease agreement specifies that the lessee is responsible for the upkeep and repairs of the building no state funds shall be used for that purpose.
6. Sponsor shall request reimbursement of eligible project costs on forms provided by the State. All reimbursement requests are required to include a copy of the invoices for the materials or services. The reimbursement request will be submitted no more than once a month.
7. The Sponsor's acceptance of this Agreement shall comprise a Grant Agreement, as provided by the Transportation Code, Chapter 21, constituting the contractual obligations and rights of the State of Texas and the Sponsor with respect to the accomplishment of the airport maintenance and compliance with the assurances and conditions as provided. Such Grant Agreement shall become effective upon the State's written Notice to Proceed issued following execution of this agreement.

#### **PART IV - Nomination of the Agent**

1. The Sponsor designates the State as the party to receive and disburse all funds used, or to be used, in payment of the costs of the project, or in reimbursement to either of the parties for costs incurred.
2. The State shall, for all purposes in connection with the project identified above, be the Agent of the Sponsor. The Sponsor grants the State a power of attorney to act as its agent to perform the following services:
  - a. accept, receive, and deposit with the State any and all project funds granted, allowed, and paid or made available by the Sponsor, the State of Texas, or any other entity;
  - b. enter into contracts as necessary for execution of scope of services;
  - c. if State enters into a contract as Agent: exercise supervision and direction of the



project work as the State reasonably finds appropriate. Where there is an irreconcilable conflict or difference of opinion, judgment, order or direction between the State and the Sponsor or any service provider, the State shall issue a written order which shall prevail and be controlling;

- d. receive, review, approve and pay invoices and payment requests for services and materials supplied in accordance with the State approved contracts;
- e. obtain an audit as may be required by state regulations; the State Auditor may conduct an audit or investigation of any entity receiving funds from TxDOT directly under this contract or indirectly through a subcontract under this contract. Acceptance of funds directly under this contract or indirectly through a subcontract under this contract acts as acceptance of the authority of the State Auditor, under the direction of the legislative audit committee, to conduct an audit or investigation in connection with those funds. An entity that is the subject of an audit or investigation must provide the state auditor with access to any information the state auditor considers relevant to the investigation or audit.
- f. reimburse sponsor for approved contract maintenance costs no more than once a month.

#### **PART V - Recitals**

1. This Grant is executed for the sole benefit of the contracting parties and is not intended or executed for the direct or incidental benefit of any third party.
2. It is the intent of this grant to not supplant local funds normally utilized for airport maintenance, and that any state financial assistance offered under this grant be in addition to those local funds normally dedicated for airport maintenance.
3. This Grant is subject to the applicable provisions of the Transportation Code, Chapters 21 and 22, and the Airport Zoning Act, Tex. Loc. Govt. Code Ann. Sections 241.001 et seq. (Vernon and Vernon Supp.). Failure to comply with the terms of this Grant or with the rules and statutes shall be considered a breach of this contract and will allow the State to pursue the remedies for breach as stated below.
  - a. Of primary importance to the State is compliance with the terms and conditions of this Grant. If, however, after all reasonable attempts to require compliance have failed, the State finds that the Sponsor is unwilling and/or unable to comply with any of the terms of this Grant, the State, may pursue any of the following remedies: (1) require a refund of any financial assistance money expended pursuant to this Grant, (2) deny Sponsor's future requests for aid, (3) request the Attorney General to bring suit seeking reimbursement of any financial assistance money expended on the project pursuant to this Grant, provided however, these

remedies shall not limit the State's authority to enforce its rules, regulations or orders as otherwise provided by law, (4) declare this Grant null and void, or (5) any other remedy available at law or in equity.

- b. Venue for resolution by a court of competent jurisdiction of any dispute arising under the terms of this Grant, or for enforcement of any of the provisions of this Grant, is specifically set by Grant of the parties in Travis County, Texas.
4. The State reserves the right to amend or withdraw this Grant at any time prior to acceptance by the Sponsor. The acceptance period cannot be greater than 30 days after issuance unless extended by the State.
5. This Grant constitutes the full and total understanding of the parties concerning their rights and responsibilities in regard to this project and shall not be modified, amended, rescinded or revoked unless such modification, amendment, rescission or revocation is agreed to by both parties in writing and executed by both parties.
6. All commitments by the Sponsor and the State are subject to constitutional and statutory limitations and restrictions binding upon the Sponsor and the State (including Sections 5 and 7 of Article 11 of the Texas Constitution, if applicable) and to the availability of funds which lawfully may be applied.

**Part VI - Acceptances**

**Sponsor**

The City of Amarillo, Texas, does ratify and adopt all statements, representations, warranties, covenants, agreements, and all terms and conditions of this Grant.

Executed this \_\_\_\_\_ day of \_\_\_\_\_, 20\_\_.

The City of Amarillo, Texas  
Sponsor

\_\_\_\_\_  
Witness Signature

\_\_\_\_\_  
Sponsor Signature

\_\_\_\_\_  
Witness Title

\_\_\_\_\_  
Sponsor Title

**Certificate of Attorney**

I, \_\_\_\_\_, acting as attorney for the City of Amarillo, Texas, do certify that I have fully examined the Grant and the proceedings taken by the Sponsor relating to the acceptance of the Grant, and find that the manner of acceptance and execution of the Grant by the Sponsor, is in accordance with the laws of the State of Texas.

Dated at \_\_\_\_\_, Texas, this \_\_\_\_\_ day of \_\_\_\_\_, 20\_\_.

\_\_\_\_\_  
Witness Signature

\_\_\_\_\_  
Attorney's Signature

\_\_\_\_\_  
Witness Title

**Acceptance of the State**

Executed by and approved for the Texas Transportation Commission for the purpose and effect of activating and/or carrying out the orders, established policies or work programs and grants heretofore approved and authorized by the Texas Transportation Commission.

STATE OF TEXAS  
TEXAS DEPARTMENT OF TRANSPORTATION

By: \_\_\_\_\_

Date: \_\_\_\_\_

**Attachment A  
Scope of Services  
TxDOT Project ID: M1704AMRI**

<b>Eligible Scope Item:</b>	<b>Estimated Costs Amount A</b>	<b>State Share Amount B</b>	<b>Sponsor Share Amount C</b>
<b>GENERAL MAINTENANCE</b>	\$100,000.00	\$50,000.00	\$50,000.00
Special Project	\$0.00	\$0.00	\$0.00
Special Project	\$0.00	\$0.00	\$0.00
Special Project	\$0.00	\$0.00	\$0.00
Special Project	\$0.00	\$0.00	\$0.00
Special Project	\$0.00	\$0.00	\$0.00
<b>TOTAL</b>	\$100,000.00	\$50,000.00	\$50,000.00

Accepted by: The City of Amarillo, Texas

\_\_\_\_\_  
Signature

Title: \_\_\_\_\_

Date: \_\_\_\_\_

GENERAL MAINTENANCE: As needed, Sponsor may contract for services/purchase materials for routine maintenance/improvement of airport pavements, signage, drainage, AWOS systems, approach aids, lighting systems, utility infrastructure, fencing, herbicide/application, sponsor owned and operated fuel systems, hangars, terminal buildings and security systems; professional services for environmental compliance, approved project design. Special projects to be determined and added by amendment.

**Only work items as described in Attachment A, Scope of Services of this Grant are reimbursable under this grant.**

**CERTIFICATION OF AIRPORT FUND**

TxDOT Project ID: M1704AMRI

The City of Amarillo does certify that an Airport Fund has been established for the Sponsor, and that all fees, charges, rents, and money from any source derived from airport operations will be deposited for the benefit of the Airport Fund and will not be diverted for other general revenue fund expenditures or any other special fund of the Sponsor and that all expenditures from the Fund will be solely for airport purposes. The fund may be an account as part of another fund, but must be accounted for in such a manner that all revenues, expenses, retained earnings, and balances in the account are discernible from other types of moneys identified in the fund as a whole.

The City of Amarillo, Texas  
(Sponsor)

By: Michael W. Conner

Title: Director of Aviation

Date: 6-16-2017

**Certification of State Single Audit Requirements**

I, Michael W. Conner, do certify that the City of Amarillo will comply with all  
(Designated Representative)

requirements of the State of Texas Single Audit Act if the City of Amarillo spends or receives more than the threshold amount in any grant funding sources during the most recently audited fiscal year. And in following those requirements, the City of Amarillo will submit the report to the audit division of the Texas Department of Transportation. If your entity did not meet the threshold in grant receivables or expenditures, please submit a letter indicating that your entity is not required to have a State Single Audit performed for the most recent audited fiscal year.

Michael W. Conner  
Signature

Director of Aviation  
Title

6-16-2017  
Date

**DESIGNATION OF SPONSOR'S AUTHORIZED REPRESENTATIVE**

TxDOT Project ID: M1704AMRI

The City of Amarillo designates, \_\_\_\_\_  
(Name, Title)

as the Sponsor's authorized representative, who shall receive all correspondence and documents associated with this grant and who shall make or shall acquire approvals and disapprovals for this grant as required on behalf of the Sponsor.

The City of Amarillo, Texas  
(Sponsor)

By: \_\_\_\_\_

Title: \_\_\_\_\_

Date: \_\_\_\_\_

**DESIGNATED REPRESENTATIVE**

Mailing Address: \_\_\_\_\_

\_\_\_\_\_

\_\_\_\_\_

Overnight Mailing Address: \_\_\_\_\_

\_\_\_\_\_

\_\_\_\_\_

Telephone/Fax Number: \_\_\_\_\_

\_\_\_\_\_

Email address: \_\_\_\_\_

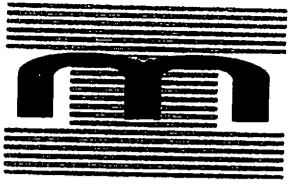

# MYSLIK, INC.

SPECIALIZING IN SNOW, ICE & FOD CONTROL EQUIPMENT

22751 Sunrise Drive  
Morrison, CO 80465  
Ph. 303-697-9692 Fax: 303-697-9693

Date: 14 Jun 2017  
Quotation #: 061417SC (1)  
Customer ID: Fort Bragg

Quotation valid until: 12/31/2017

Prepared by: SC

Quotation For: Thomas Oscarsson  
Rick Husband Amarillo IAP  
806-335-1671  
[thomas.oscarsson@amarillo.gov](mailto:thomas.oscarsson@amarillo.gov)

SALESPERSON	P.O. NUMBER	SHIP DATE	SHIP VIA	F.O.B. POINT	TERMS
SC		10-14 days ARO	Truck	Amarillo, TX	30 Days

ITEM NUMBER	DESCRIPTION	Price ea.	Qty	Ext Price
1	TFB-22GF Triplex System	\$17,800.00	2	\$35,600.00
2	Freight Expense No Charge	\$0.00		\$0.00
	TFB-22GF Includes: 3 Storage/Roller Bags, 3FB-0 FOD*BOSS Mats w/Mesh Covers, FB-82 Triplex Trailer with Tow Ring, 3 FB-120 Fround Force Hitches, Gloves, Repair Webbing & Operators Manual.			
	The price is contingent on 2 Triplex Systems purchased at the same time and shipped to the same location.			
<b>TOTAL</b>				<b>\$35,600.00</b>

Please add 3% processing fee if using credit card for purchase.

Should you have any questions regarding this quotation please contact me.

Thank you very much for the opportunity,

Sincerely,

*Steven J. Clark*

Phone: 702-685-6656

Cell: 480-286-4242

Fax: 702-396-6065

Email: [sclark@myslikinc.com](mailto:sclark@myslikinc.com)



Standard Signs, Inc.  
 9115 Freeway Drive  
 Macedonia, OH 44056  
 (800) 258-1997



AIRPORT: Rick Husband Amarillo International Airport, TX  
 DATE: 6/6/2017  
 QUOTED BY: Melanie Rostankowski

<u>ITEM</u>	<u>QTY</u>	<u>DESCRIPTION</u>	<u>UNIT PRICE</u>	<u>EXTENSION</u>
1		Lumacurve Size 3 Replacement Panels		
		Includes:		
	7	LCLT-5YRP: LUMACURVE ® Reflective Legend Panels, Size 3, Directional	\$ 347.82	\$ 2,434.74
	2	LCLT-5LRP: LUMACURVE ® Reflective Legend Panels, Size 3, Location	\$ 347.82	\$ 695.64
	9	LCLT-5RORP: LUMACURVE ® Reflective Legend Panels, Size 3, Mandatory	\$ 368.72	\$ 3,318.48
			<b>TOTAL = \$</b>	<b>6,448.86</b>

NOTES

INSTALLATION NOT INCLUDED  
 QUOTATION IS FOR LISTED MATERIALS ONLY.

\* All panels and sign parts quoted are Lumacurve original manufacturer's equipment.  
 Use of 3<sup>rd</sup> party (non OEM) panels or parts is not FAA certified for use in Lumacurve signs.  
 Call (330) 467-2030 with questions or Consult the FAA website for a current listing of FAA Certified Equipment:  
[http://www.faa.gov/airports\\_airtraffic/airports/resources/advisory\\_circulars/](http://www.faa.gov/airports_airtraffic/airports/resources/advisory_circulars/)

TERMS:

PAYMENT: NET 30 DAYS (w/ approved credit)

FREIGHT: Prepaid & Added for orders < \$2500.  
 Allowed for orders > \$2500.  
 Pricing is for (1) purchase consigned to (1) location within the contiguous 48 US states.

DELIVERY: Standard Lead-Time is 2 weeks\* after receipt of released purchase order & approved shop drawings.  
 \*May exceed 2 weeks depending on quantities, product mix, and/or special requirements.

VALID FOR 30 DAYS



5/23/17

REVISED

Quoted To: Eric Ozier / Amarillo Airport

From: Jon Sproul

TTB 1325 Type III Airport Beads – 3,000 lbs \ Price	\$2.77 / lb	\$8,310
TTB 1325 Type I Airport Beads – 2,700 lbs \ Price	\$0.38 / lb	\$1,026

Prices are FOB Destination. (Assumes above 2 items will ship as one order / shipment)

Leadtime: 15 days ARO

Quote Valid for 90 days.

\$ 9,336.<sup>00</sup>

Please let us know if we can be of further assistance.

Best Regards,

Jon Sproul

## BOARDS AND COMMISSIONS – VACANCIES



### Amarillo Local Government Corporation

03/22/2011 Les Simpson 09/30/2017 (resigned)

### Amarillo-Potter Events Venue District:

11/01/2002 Glenn McMennamy 10/01/2017 (resigned)

### Board of Review – Landmarks & Historic District (3-year terms)

06/11/2014 Chan Davidson 05/21/2017

06/08/2014 Trey Porter 05/21/2017

### Community Development Advisory Committee (2-year term)

02/01/2005 Glenda Grisham 12/31/2016 NW

02/13/2007 Rita Saldierna 12/31/2016 NE

12/20/2011 Sabrina Sisneros 12/31/2016 SE

### Convention & Visitor Council

03/02/2017 Suzanne Talley 09/30/2018 (resigned)

### Council Audit Committee

04/12/2016 Paul Harpole 04/11/2017 (resigned)

04/12/2016 Mark Nair 04/11/2017 (resigned)

### Council Subcommittee on Economic Development Incentive Policies and Guidelines

04/12/2016 Terry Childers 04/11/2017 (position appointment)

04/12/2016 Bob Cowell 04/11/2017 (position appointment)

04/12/2016 Elisha Demerson 04/11/2017 (position appointment)

04/12/2016 Randy Burkett 04/11/2017 (position appointment)

### Parks and Recreation Board (3-year terms)

08/19/2014 George DeCoux 07/01/2017

09/06/2016 Terry Price 07/01/2017

### Planning and Zoning Commission (3-year terms)

05/14/2014 Rob Parker 05/15/2017

05/14/2014 Dean Bedwell 05/15/2017

06/21/2017